

Air Force Institute of Technology

AFIT Scholar

Theses and Dissertations

Student Graduate Works

3-2003

An Economic Evaluation of Binary Cycle Geothermal Electricity Production

Crissie D. Fitzgerald

Follow this and additional works at: <https://scholar.afit.edu/etd>



Part of the [Power and Energy Commons](#), and the [Sustainability Commons](#)

Recommended Citation

Fitzgerald, Crissie D., "An Economic Evaluation of Binary Cycle Geothermal Electricity Production" (2003). *Theses and Dissertations*. 4219. <https://scholar.afit.edu/etd/4219>

This Thesis is brought to you for free and open access by the Student Graduate Works at AFIT Scholar. It has been accepted for inclusion in Theses and Dissertations by an authorized administrator of AFIT Scholar. For more information, please contact richard.mansfield@afit.edu.



**AN ECONOMIC EVALUATION OF BINARY CYCLE
GEOTHERMAL ELECTRICITY PRODUCTION**

THESIS

Crissie D. Fitzgerald, Captain, USAF

AFIT/GEE/ENV/03-07

**DEPARTMENT OF THE AIR FORCE
AIR UNIVERSITY**

AIR FORCE INSTITUTE OF TECHNOLOGY

Wright-Patterson Air Force Base, Ohio

APPROVED FOR PUBLIC RELEASE; DISTRIBUTION UNLIMITED

The views expressed in this thesis are those of the author and do not reflect the official policy or position of the United States Air Force, Department of Defense, or the United States Government.

AFIT/GEE/ENV/03-07

AN ECONOMIC ANALYSIS OF BINARY CYCLE GEOTHERMAL ELECTRICITY
PRODUCTION

THESIS

Presented to the Faculty

Department of Systems and Engineering Management

Graduate School of Engineering and Management

Air Force Institute of Technology

Air University

Air Education and Training Command

In Partial Fulfillment of the Requirements for the
Degree of Master of Science in Engineering and Environmental Management

Crissie D. Fitzgerald, BS

Captain, USAF

March 2003

APPROVED FOR PUBLIC RELEASE; DISTRIBUTION UNLIMITED.

AFIT/GEE/ENV/03-07

AN ECONOMIC EVALUATION OF BINARY CYCLE GEOTHERMAL
ELECTRICITY PRODUCTION

Crissie D. Fitzgerald, BS
Captain, USAF

Approved:



Peter T. LaPuma, Maj, USAF, Ph.D.
Chair, Advisory Committee

17 Mar 03

date



Alfred E. Thal, Jr., Lt Col, USAF, Ph.D.
Member, Advisory Committee

2 APR 03

date



Charles A. Bleckmann, Ph.D.
Member, Advisory Committee

2 Apr 03

date

Acknowledgements

Special thanks to my advisor, Maj. Peter LaPuma for his endless patience and insightful guidance throughout the course of this thesis. Thanks, sir, for all the time invested and for helping me make a little sense of it all. I would also like to thank my family for their constant support and love—you stood by me through some extremely demanding times, and I will be forever grateful. To my classmates and pals who helped me along the way, thanks to you too!

Crissie D. Fitzgerald

Table of Contents

	Page
Acknowledgements	iv
List of Figures	vi
List of Tables	vii
Abstract.....	viii
I. Introduction	1
Problem Statement.....	1
Research Objectives	5
Methodology.....	5
Preview of Chapters	6
II. Literature Review	8
Geothermal Electricity Generation.....	8
Resource Type	10
Resource Temperature.....	13
Power Plant Type	16
Power Plant Size	19
Specific Cost Variables.....	22
III. Methodology	26
Overview	26
Payback Analysis	29
Breakeven Electricity Sales Rate Analysis	29
Variable Distribution Development	30
IV. Results	37
Overview	37
Payback Analysis Results	37
Constant Temperature Median Payback Periods	40
Constant Diameter Median Payback Analysis	43
Breakeven Analysis Results	45
V. Discussion	51
Limitations and Future Research.....	52
Conclusions.....	53
Appendix A. Payback Analysis Tabular Data.....	55
Appendix B. Breakeven Sales Rate Analysis Tabular Results.....	64
Bibliography	67
Vita.....	70

List of Figures

	Page
Figure 1. U.S. Electricity Generation by Source.....	2
Figure 2: Simplified Rankine Cycle	8
Figure 3. Geothermal Power Plant.....	9
Figure 4. Mean Geothermal Gradient, Upper 1 to 3 km of the Crust.....	14
Figure 5. Soil Temperature Variations by Depth	15
Figure 6. Mean Ground Temperature (°F) at 15 Feet Below the Surface	15
Figure 7. Dry Steam Power Plant.....	17
Figure 8. Flash Steam Power Plant	17
Figure 9. Binary Cycle Power Plant	17
Figure 10. Net Generating Capacity of a Binary Cycle Power Plant	20
Figure 11. Methodology Influence Diagram	27
Figure 12. Scenario Matrix.....	28
Figure 13. Cost Distribution for Generating Equipment.....	31
Figure 14. Cost Distribution for Pumps & Gathering System	32
Figure 15. Cost Distribution for Well Drilling & Installation	34
Figure 16. Sample Probability Distribution	38
Figure 17. Payback Curves for 200°C Resource Temperature and 3,495 lit/min Flow Rate	39
Figure 18. Payback Curve Comparison Chart for 200°C Resource Temperature	40
Figure 19. Constant Temperature Payback Curve Comparison Charts	42
Figure 20. Constant Flow Rate Payback Curve Comparison Charts	44
Figure 21. Breakeven Sales Rate Results for 160°C Resource Temperature and 322 lit/min Flow Rate	46
Figure 22. Breakeven Sales Rates by Scenario	48

List of Tables

	Page
Table 1. Summary of Geothermal Power Plants in the U.S.	19
Table 2. Maximum Attainable Flow Rates for Submersible Pumps.....	21
Table 3. Cost Drivers for Binary Power Plants.....	24
Table 4. Distributions Assigned to Specific Cost Drivers	30

Abstract

The U.S. is heavily dependent on fossil fuels to produce electricity. Geothermal energy, the heat in the earth's crust, can provide an alternative source of energy for electricity production as well as reduce fossil fuel consumption.

The economic analysis presented in this study focuses on binary cycle geothermal electricity production. Variables such as well flow rate, geothermal gradient and electricity prices were varied to study their influence on the economic payback period for binary cycle geothermal electricity production. Payback periods represent the amount of time (in years) necessary to recover initial costs of plant construction.

Well flow rate has the greatest influence on economic results. A 10-year payback period can be achieved with almost any scenario as long as the electricity sales rates are above 6 cents/kWh and the well flow rate is high (16,649 lit/min). At a more modest flow rate (3,459 lit/min), most scenarios have payback periods below 20 years as long as sales rates are above 6 cents/kWh. However, at the lowest flow rate (322 lit/min), no scenario results in a payback less than 20 years unless electricity sales prices reach at least 17 cents/kWh. Because geothermal gradient is not as influential as flow rate, a large fraction of the U.S. with modest thermal gradients can economically produce geothermal electricity as long as site conditions allow high flow rates.

AN ECONOMIC EVALUATION OF BINARY CYCLE GEOTHERMAL ELECTRICITY PRODUCTION

I. Introduction

Problem Statement

Although the U.S. population is less than 5% of the world population, it is responsible for nearly 25% of the worldwide energy consumption (Bureau of the Census, 2000; Department of Energy, 2001). In 2001, the U.S. consumed 97 quadrillion British Thermal Units (BTUs) of energy (nearly 340 million BTU per person), 86% of which was fossil fuel based (Department of Energy, 2001). The U.S. Department of Energy (DoE) expects energy consumption to grow 1.5% annually over the next 17 years, with total energy consumption reaching an estimated 130 quadrillion BTU by the year 2020 (Department of Energy, 2003). The heavy reliance on depletable fossil energy resources along with a growing demand for energy demonstrates the need for renewable energy sources.

Electricity generation consumes a large portion of fossil energy in the U.S. Of the total energy used in 2001, 40% (3500 billion kilowatt hours (kWh)) was consumed for electricity generation (Department of Energy, 2001). DoE estimates indicate that electricity demand will increase 1.5% annually, reaching over 5200 billion kWh by 2025 (Department of Energy, 2003).

The electricity generated to meet demand in the U.S. comes from a variety of sources. Figure 1 shows that of the total electricity consumed in 2001, 70%

was generated from fossil fuels with another 20% from nuclear energy. Forecasts through the year 2025 indicate that the percentage of electricity generated from nuclear and hydroelectric sources will not change significantly. Natural gas generation plants are expected to take on a larger share of the generating capacity (contributing 29% of electricity production in 2025 from 17% in 2001). Despite the increase in natural gas usage, coal will likely remain the largest source of electricity over the next 22 years, though the percentage contribution is predicted to decrease from 52% in 2001 to 47% by 2025 (Department of Energy, 2003).

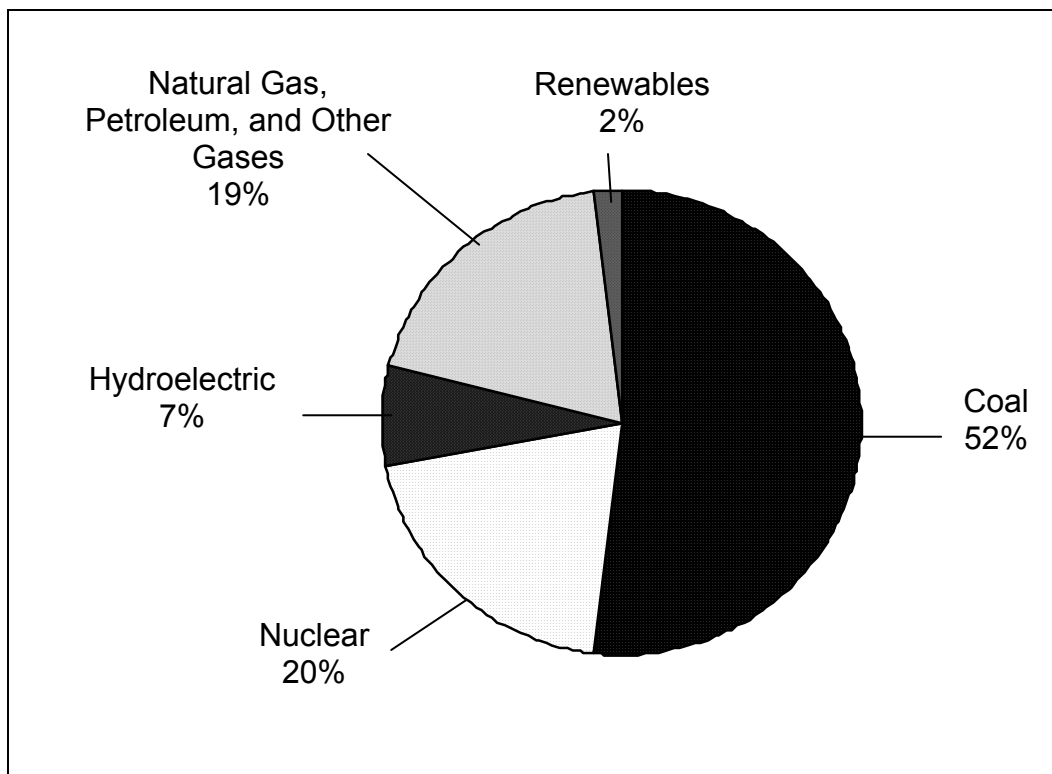

Figure 1. U.S. Electricity Generation by Source
(Department of Energy, 2003)

There is a great opportunity to reduce U.S. dependence on fossil energy by developing renewable energy sources to produce electricity (Department of Energy, 2001). The most prominent renewable sources include biomass, wind, solar, and geothermal. Technology advancements in the past 10 years have made these renewable sources more attractive options to replace fossil fuels as generation sources. However, because renewable sources tend to have higher initial capital investment costs, they have historically not been able to compete with fossil fuel generation plants in terms of the cost to produce electricity.

In an attempt to reduce the dependence on depletable fossil fuels and encourage environmentally responsible alternatives, the U.S. government has taken steps to promote the use of renewable sources through legislation. Current energy policy has set forth goals of modernizing infrastructure and increasing energy supplies while focusing on protection and improvement of the environment (National Energy Policy Development Group, 2001:10). Key pieces of legislation that support these goals are outlined below.

Legislation

Clean Air Act Amendments of 1990

The Clean Air Act (CAA) has evolved into a set of standards detailing air pollution control requirements for many industries. A primary focus of the CAA Amendments (CAAA) implemented in 1990 was to reduce emissions from the generation of electricity. As an example, emission reduction legislation contained

in the CAAA required coal fired power plants to substantially reduce annual sulfur dioxide emissions and nitrogen oxide emissions (Edinger and Kaul, 2000:306).

Energy Policy Act

The Energy Policy Act (EPACT) of 1992 covered a wide range of energy issues. The provisions in this act relating to renewable energy were written to promote increases in the production and utilization of energy from renewable energy sources (United States Congress, 1992). The EPACT also instituted an energy tax credit for solar and geothermal projects. Environmental provisions within this act that discuss global warming issues also indirectly support the advancement of renewable energies that help reduce the occurrence of smog, acid rain, or greenhouse gas emissions (Edinger and Kaul, 2000:307).

Executive Order (EO) 13123

Recognizing the federal government as the nations' largest consumer of energy, EO 13123, "Greening the Government Through Efficient Energy Management," was implemented in 1999. EO 13123 builds on the foundation of EPACT and establishes energy efficiency goals for federal facilities. EO 13123 set forth goals to reduce greenhouse gas emissions, improve energy efficiency, reduce energy consumption and expand the use of renewable energy. Specific goals to reduce greenhouse gas emissions 30% by the year 2010 as compared to the baseline set in 1990 were established. Other specific goals include reducing energy consumption per square foot in federal facilities by 35% by the year 2010 (using a 1985 baseline) and installing 20,000 solar energy systems in

federal facilities by 2010. EO 13123 also promotes the use of life cycle cost analysis to measure the impact of reduction programs (Clinton, 1999).

Geothermal electricity production is a renewable alternative that can be implemented to meet the goals of the legislation outlined above, as well as decrease national dependence on fossil fuels. Geothermal electricity production uses naturally occurring heat in the earth's crust as a fuel source to generate electricity. Electricity production through geothermal sources also has less negative environmental impacts than conventional fossil fuel generation sources.

Research Objectives

In order to analyze the economic impact of geothermal electricity as a renewable energy source, this research will provide a basis for decision makers to evaluate the feasibility of geothermal electricity generation by:

1. Evaluating the payback period of a binary cycle geothermal power plant given different physical site characteristics and different electricity sales prices.
2. Conducting a breakeven analysis to determine the electricity sales rate that must be achieved to recover the total life cycle costs of a binary cycle geothermal power plant given different physical site characteristics.
3. Determining the degree of influence from key input variables on the payback and breakeven analysis output.

Methodology

In order to achieve the research objectives, different design scenarios will be analyzed based on physical site characteristics applicable to a geothermal power plant. Within each design scenario, Monte Carlo simulation techniques

will be used to evaluate the impact of variables influencing geothermal power plant construction and operation costs. Payback periods and breakeven electricity sales rates will be calculated for each scenario.

Monte Carlo simulation allows the modeler to input probability distributions for input variables to account for uncertainty and variability inherent in real-world situations. The type of distribution selected depends on the type of information available and condition surrounding the variable (Decisioneering, 2001:59).

When the simulation is run, an input value is randomly selected within the assigned distributions and an output is recorded for each iteration. The summation of many iterations (10,000 iterations in this study) provides a probability distribution for each output. This probabilistic approach more closely approximates real-world behavior by incorporating variability in the analysis. The software used in this study to run Monte Carlo simulation is Crystal Ball 2000 from Decisioneering, Inc., which works in conjunction with Microsoft Excel.

Preview of Chapters

Chapter 2 will discuss the various physical site conditions used in determining the selected scenarios for analysis, as well as the specific variables that drive the costs of geothermal power plant construction and operation.

Chapter 3 shows how the selected design scenarios and cost data interact in the simulations, as well as the method used to calculate payback periods and the breakeven electricity sales rate. Chapter 4 will display results of the analyses,

and finally, Chapter 5 will provide recommendations and conclusions relating to the research objectives.

II. Literature Review

Geothermal Electricity Generation

Geothermal electricity generation is based on the same principles used in fossil fuel electricity generating plants: the Rankine Cycle. A simplified Rankine Cycle is illustrated in Figure 2 and consists of a boiler, turbine, condenser, and pump. Fuel heats a liquid (generally water) in the boiler, which turns to steam. The resulting steam is then used to drive a turbine connected to the generator that produces electricity. The fluid is then condensed to a liquid in the condenser and the cycle restarts. The only difference between a fossil fuel plant and the geothermal plant is the type of fuel used to generate heat in the boiler.

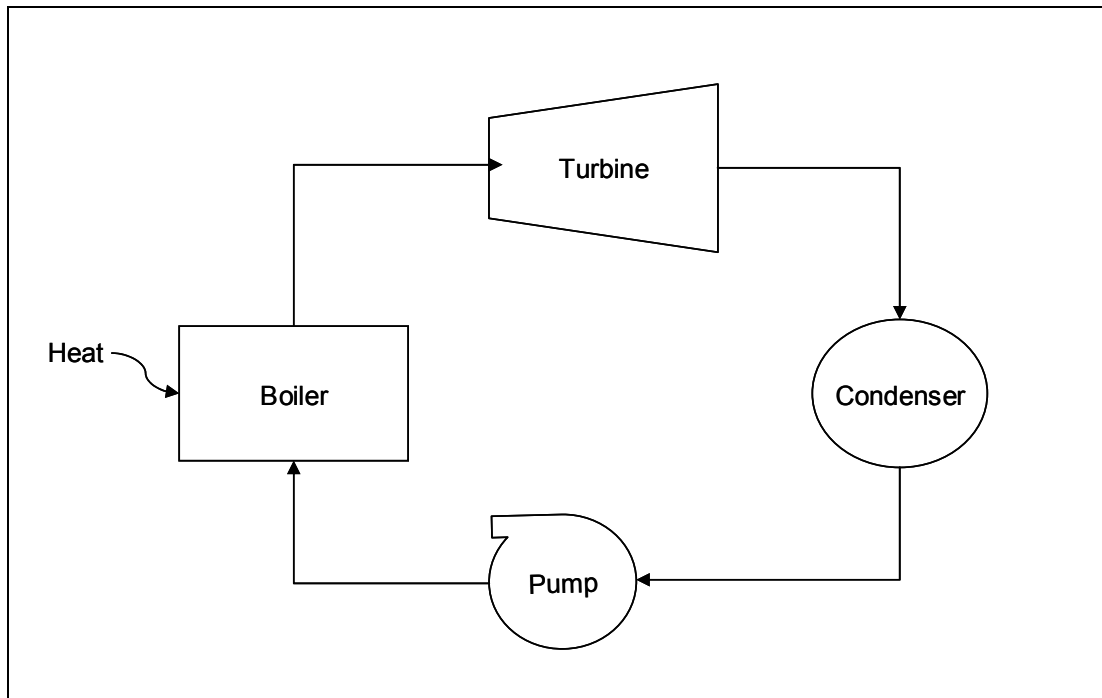

Figure 2: Simplified Rankine Cycle

A basic geothermal power plant is shown in Figure 3. Heated water drawn from a production well is brought to the surface and is pumped from the wellhead to the generating equipment. After the water or steam has passed through the turbine and condenser, the condensed water is pumped back into the reservoir via an injection well.

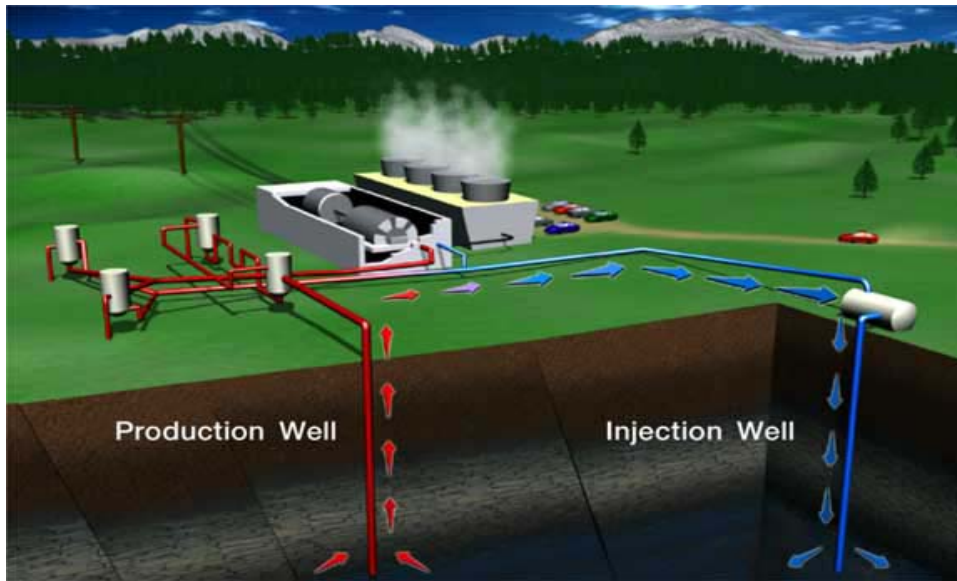

Figure 3. Geothermal Power Plant
(Geothermal Education Office, 2003)

Geothermal electricity generation is advantageous from an environmental perspective when compared to fossil fuel electricity production. The Department of Energy reviewed studies performed on plant operation from 1995 to 1998 and found that the power produced from currently installed geothermal energy in the United States displaces the emissions of 22 million tons of carbon dioxide, 200,000 tons of sulfur dioxide, 80,000 tons of nitrogen oxides, and 110,000 tons of particulate emissions per year compared with the production of the same amount of electricity from an average U.S. coal-fired plant (Wright, 1998:734).

While geothermal energy is considered a renewable resource, over-production can decrease the thermal energy of the geothermal reservoir (Mock et al., 1997:308). Statistics from The Geysers Geothermal Area in California show a marked decrease in steam pressure that coincided with accelerated power production (Wright, 1998:735-736). However, proper designs and creative re-injection techniques can mitigate these depletion effects (Mock et al., 1997:308).

Total life cycle costs of geothermal power plant construction and operation are dependent on several factors. Physical factors such as resource type, temperature and productivity determine the energy potential at a given location and drive initial capital costs of the energy gathering system (specifically, the number of wells that must be drilled and the depth and diameter of each well). The combination of these factors determines the type and size of plant that can be constructed at a given location. Other initial capital costs include the costs associated with resource identification and exploration, and the necessary fees for siting and licensing of the plant. Annual operations and maintenance (O&M) fees add costs over the lifetime of the plant (DiPippo, 1998:8.53). The following sections provide an in depth description of each of the physical factors that drive plant type and size, which ultimately influence the cost of geothermal power plant construction.

Resource Type

Geothermal resources are classified according to natural geologic attributes using four major categories: hydrothermal, geopressured, hot dry rock,

and magma resources (Mock et al., 1997:311-312). While it is theoretically feasible that each type could be used for electricity generation, only hydrothermal systems are being commercially developed for this use, and will be the focus of this research. Technology limitations have prevented geopressured, hot dry rock, and magma systems from becoming cost competitive and have limited their implementation.

Hydrothermal resources refer to permeable regions of porous rock that contain either steam or water with temperatures ranging from 90°C to 350°C and usually occur at depths of 1-4 kilometers (km). Hydrothermal resources are further broken down based on temperature and phase of fluid in the resource. High temperature hydrothermal resources typically have temperatures above 150°C and may consist of both hot water and steam, though steam is the most prevalent phase. Intermediate temperature resources have temperatures between 90°C and 150°C and consist mostly of hot water, though steam is present as well. Low temperature resources are those with temperatures less than 90°C and are not suitable for electricity generation.

Geopressured resources consist of hot high-pressure water and also contain small amounts of dissolved natural gas (methane). Chemical energy from the dissolved methane can also be used to produce energy. Geopressured resources typically occur in areas abundant in petroleum resources so geopressured resources are limited. In the U.S., geopressured resources occur in the Gulf Coast regions of Louisiana and Texas where temperatures between 150°C and 180°C can be reached at depths between 3-5 km. Approximately

32% of the total energy content of these resources comes from the chemical energy in the methane (Mock et al., 1997:312).

Hot dry rock (HDR) refers to areas that do not contain fluids, but rock temperatures are high enough to produce water temperatures in the range required to generate electricity if water were injected into the fissures and fractures of the rock. Hypothetically, HDR resources are present in any area just by drilling sufficiently deep to reach appropriate rock temperatures necessary to heat water and produce electricity. HDR systems typically occur at depths of 2-8 km (Mock et al., 1997:311-312). HDR has not been developed commercially because technology has not become available that would ensure sufficient flow through the fractured rock to maintain electricity production. Also, the high costs associated with drilling through the rock makes this type of resource economically undesirable (Mock et al., 1997:334)

Magma resources occur where molten rock can be found at accessible depths (less than 7 km). These resources are abundant in volcanically active areas such as the mountainous western U.S. Magma resources are especially attractive because their extreme temperatures (usually greater than 650°C) allow for very efficient electricity generation (Mock et al., 1997:312). These temperatures, however, have also limited the development of magma resources. Materials currently used in the drilling and well development process (drill bits, well casing etc.) cannot withstand these extreme temperatures, and the costs associated with using more robust materials limit economic competitiveness of this resource type (Mock et al., 1997:341).

Resource Temperature

The actual temperature that can be reached at depth in a hydrothermal resource is a function of the geothermal gradient at a given location and determines the amount of heat available to produce electricity. Heat generated at the earth's core by decaying radioactive material moves toward the surface through conductive heat flow (Fridleifsson, 1996:1; Mock et al., 1997:307). As the thermal energy moves outward from the center of the earth, the fluids and solids in the underground matrix are heated. A thermal gradient occurs because the ground is cooler near the surface and becomes warmer with increasing depth. This temperature differential is referred to as the geothermal gradient and is used to determine the quality of geothermal resources. A higher thermal gradient is preferred because less depth is required to reach reservoir temperatures capable of producing electricity. All things being equal, to obtain the same water temperature at depth, a gradient of 30°C/km would require twice the drilling depth as a gradient of 60°C/km. As seen in Figure 4, the geothermal gradient in the U.S. varies roughly from 10°C/km to 75°C/km, with a national average of approximately 30°C/km.

Most of the areas with high geothermal gradients (areas with darkest shading) are located in the mountainous areas of the western U.S. The specific water temperature of the resource at depth is calculated using Equation 1.

$$\text{Resource Temp} = \text{Well Depth} * \text{Geothermal Gradient} + \text{Ground Temperature} \quad (1)$$

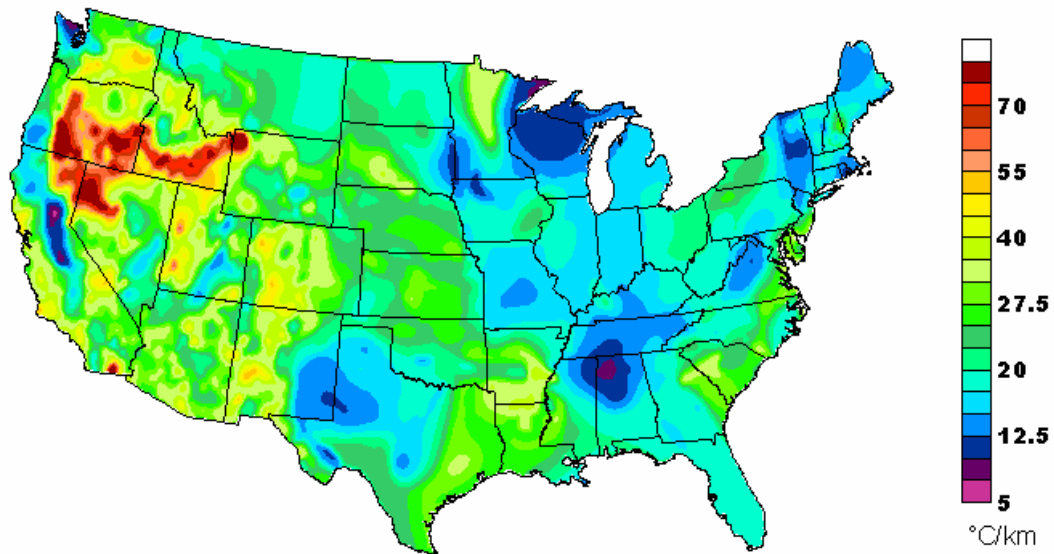

Figure 4. Mean Geothermal Gradient, Upper 1 to 3 km of the Crust
(Blackwell et al., 1997)

At the surface, ground temperature fluctuates by location with the ambient air temperature. However, ground temperatures 10-15 feet (3-4.5 meters) below the surface vary significantly less and eventually reach a stable temperature at about 28 feet (8.5 meters) as shown in Figure 5. As seen in Figure 6, ground temperatures 15 feet below the surface (4.5 meters) range roughly from 40-72°F (4-22°C) depending on the location within the U.S. Because this research does not focus on a specific location, but instead applies general parameters to the model, ground temperature will be considered a constant 56°F (13°C), which is the midpoint of the range shown in Figure 6.

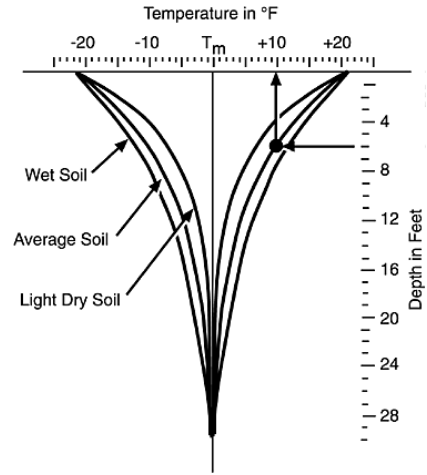

Figure 5. Soil Temperature Variations by Depth
(Department of Energy, 1994)

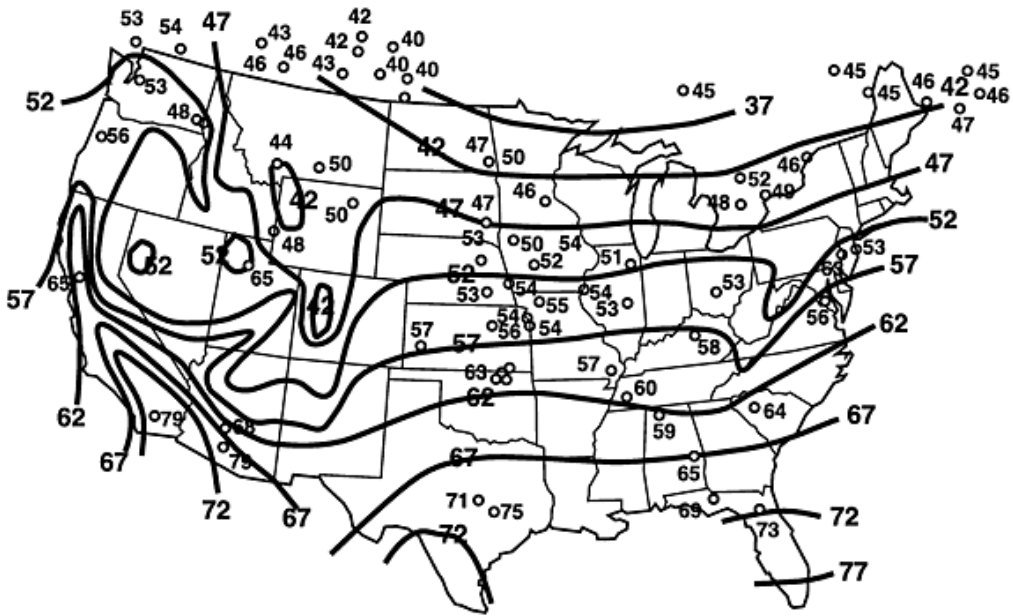

Figure 6. Mean Ground Temperature (°F) at 15 Feet Below the Surface
(Department of Energy, 1994)

Power Plant Type

The DoE Geothermal Energy Program recognizes three types of geothermal power plants: dry steam plants, flash steam plants, and binary cycle plants. The temperature of the hydrothermal resource determines the type of plant used. A more detailed description of each plant is given in this section.

Dry steam (DS) plants (Figure 7) are the most efficient of the three plant types. DS plants are used in conjunction with high temperature vapor dominated resources, thus no additional energy must be added to convert the resource into a vapor. The steam in the reservoir is brought to the surface and is used to turn the turbine.

Flash steam (FS) plants (Figure 8) take advantage of the superheated water and vapor in high and intermediate temperature resources. In a FS plant, the water/vapor mix is pumped from the production well into a liquid-vapor separator. The vapor portion is routed directly through the turbine. The liquid portion is routed into low-pressure tanks, where the change in pressure causes the water to 'flash' into steam. This steam is then routed to the turbine. Within a FS system, this process of routing liquid through a flash chamber can be repeated multiple times, resulting in either a single or double flash cycle (Mock et al., 1997:323).

Binary-cycle plants (Figure 9) differ from dry steam and flash steam plants because they do not use the steam or water from the geothermal

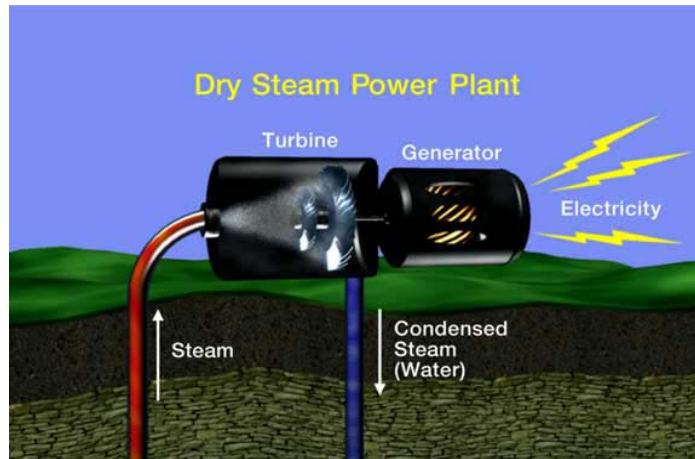

Figure 7. Dry Steam Power Plant

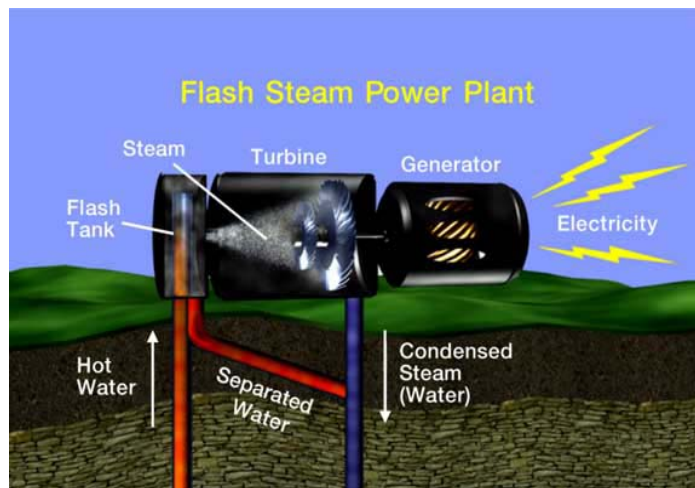

Figure 8. Flash Steam Power Plant

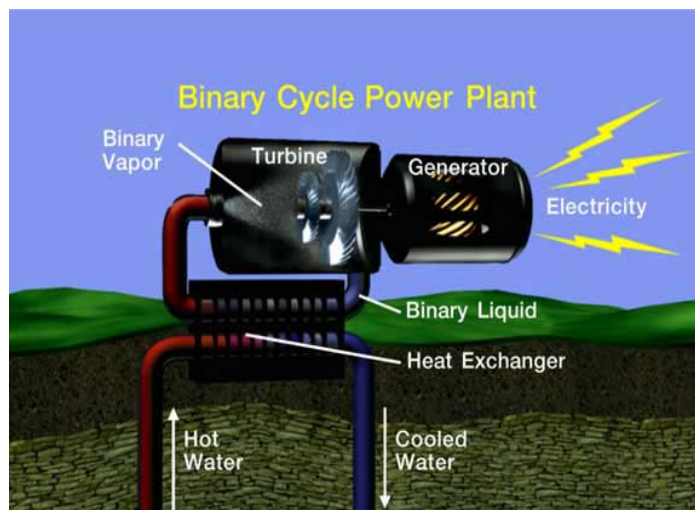

Figure 9. Binary Cycle Power Plant

(Geothermal Education Office, 2003)

reservoir directly. Instead, the geothermal fluid is contained in a closed-loop system and is pumped from the production well through a heat exchanger and routed back into the reservoir. Using the thermal energy from the geothermal fluid, a secondary working fluid (thus the term 'binary') with a significantly lower boiling point than water located within the heat exchanger is vaporized (Department of Energy, 2002). This vapor is then used to drive the turbine. Since the geothermal fluid is pumped up the production well at a constant pressure, the fluid does not change phase during transportation of the fluid from the resource to the heat exchanger. Also, the well and gathering system is designed to minimize heat loss from the resource to the heat exchanger. Therefore, it is assumed that the resource temperature is the same as the fluid temperature at the above ground heat exchanger (Combs, 2003).

In 1998, 65 geothermal power plants in the U.S. produced over 2500 Megawatts of electricity (MWe). A breakdown of plant types is shown in Table 1. All of the plants in operation exist in the western parts of the U.S. where the geothermal gradient is highest (refer to Figure 2). California has the largest geothermal generating capacity with 51 of the 65 plants operating in this state, including 22 dry steam plants. Nevada has a total of ten geothermal plants (binary and double flash systems), Utah has three geothermal plants (single flash and binary), and Hawaii has one single flash/binary hybrid plant in operation (Anderson 1998:1.110).

Of the 65 geothermal plants in operation, the 22 dry steam plants provide over 60 percent of the total installed capacity. Dry steam power plants are

Type of Plant	Number of Plants	MWe
Dry Steam	22	1623
Single Flash Steam	4	49
Double Flash Steam	21	668
Binary	16	181
Hybrid	2	55
Total	65	2576

(Elliott et al., 1998:1.118)

dominant in the U.S. because of the presence of the world's largest dry-steam field in California. Although only 16 binary power plants are operating in the U.S., they have the greatest future potential because they offer greater flexibility when operating in conjunction with intermediate temperature resources (90°C-150°C).

Power Plant Size

The size of the power plant (kilowatt (kW) rating) refers to the net generating capacity of the plant and is dependent on the amount of thermal energy available in a given location. Net generating capacity for binary cycle power plants can be calculated using resource temperature and flow rate as shown in Figure 10. For example, if the resource temperature is 200°C, and assuming a flow rate of 20 kg/s, the maximum generating capacity would be 1560 kilowatts of electricity (kWe) (78 kWe/kg/s *20 kg/s).

Attainable flow rates within a reservoir depend on the resource productivity level. Resource productivity is a function of the underground matrix at a given location and controls the amount of fluid (flow rate) that can be used in the heat transfer process. Resource productivity is driven by the ease with which

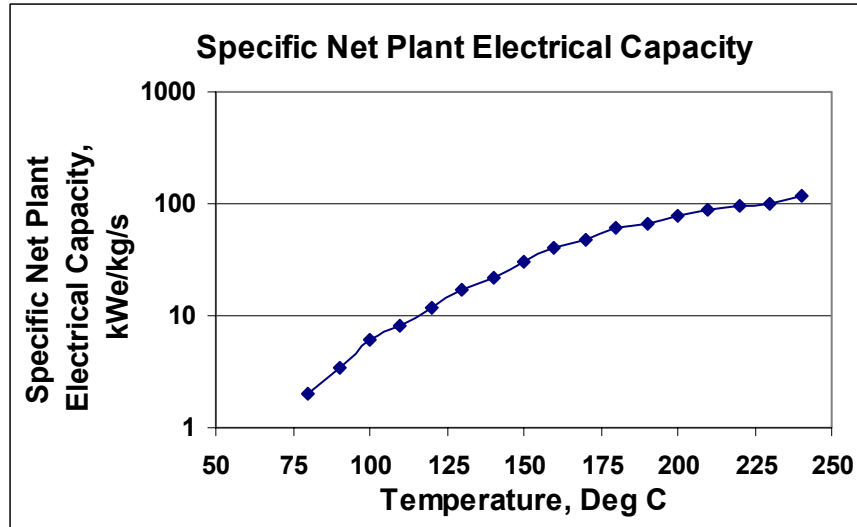

Figure 10. Net Generating Capacity of a Binary Cycle Power Plant
(Pritchett, 1998)

water can move through the underground matrix and is controlled by hydraulic parameters such as permeability, hydraulic conductivity, and hydraulic gradient (Pierzynski et al. 1994:19). For example, an underground matrix consisting mostly of solid rock will have a lower productivity (and lower potential flow rate) than an underground matrix consisting mostly of sand. Resource productivity also influences the well diameter selected during design. Well diameters are sized to provide the maximum amount of geothermal fluid (flow rate) to the generating equipment within the limits of the resource productivity level. For binary power plants, where pumps are used to move the geothermal fluid from the resource to the surface, pump type also controls the flow rate. Research indicates that for well diameters between 75mm and 300mm (inside diameter) submersible pumps provide the best attainable flow rates (Pritchett,

1997). Examples of the maximum attainable flow rates for different well diameters using submersible pumps are shown in Table 2.

Table 2. Maximum Attainable Flow Rates for Submersible Pumps

Maximum Attainable Flow Rates Submersible Pumps			
Well Inside Diameter (mm)	Maximum Flow Rate (kg/s)	Maximum Flow Rate (l/min)	Maximum Flow Rate (gal/min) ⁺
75	3.13	188	50
100	5.37	322	85
125	9.54	572	151
150	19.24	1,154	305
175	34.84	2,090	551
200	58.25	3,495	922
225	91.67	5,500	1,451
250	137.53	8,252	2,177
275	198.5	11,910	3,142
300	277.49	16,649	4,392

+ Values converted to gal/min for reference

(Pritchett, 1997)

Well diameters of 100mm, 200mm, and 300mm (highlighted in Table 2) have been selected for analysis in this study. These well diameters were selected to cover the range of feasible well diameters most typically used for geothermal systems. The maximum attainable flow rate for each of these three well diameters will be assumed for this model. The payback period and breakeven sales rate will be compared with these three flow rates to estimate the relative impact of flow rate on these economic parameters.

Specific Cost Variables

Initial capital costs of a geothermal power plant include both resource development costs as well as the costs to install the physical plant equipment. Resource development costs include identifying and classifying the resource (through resource exploration) and testing potential production wells, as well as costs for siting and licensing requirements. Physical plant costs include well drilling and installation, plant generating equipment, and the pumps and gathering system used to transport the geothermal fluid up the well and from the wellhead to the generating equipment.

In order to assign probability distributions to these variables, several previous studies were reviewed. The goals of the previous studies ranged from a basic overview of the current state of geothermal technology to examining specific costs associated with potential geothermal site development as well as costs of plants already constructed. Table 3 lists the studies reviewed, shows the specific variables that influence construction and operation costs, and shows specific values assigned to the variables in each study.

Reports published by DiPippo (1998), Barbier (2002), Kutscher (2000), and the DoE's Office of Energy Efficiency and Renewable Energy (EERE) (Undated) gave general overviews of the history, technology, and status of geothermal development. Costs provided in these reports were not related to a specific site, but were intended to give a general understanding for cost ranges and plant design parameters. These studies outlined costs associated with

different plant types; however, costs shown in Table 3 are specific to binary cycle power plants.

Gawlik and Kutscher (2000) selected 17 of the most promising sites (based on temperature and flow rate) from a previous survey that identified 271 geothermal resources located in the Western U.S. Each site was analyzed to determine the potential performance of a binary cycle power plant, and costs were assigned to the variables listed in Table 3 for each site. Costs developed in the Gawlik and Kutscher study were based on the assumption that plants would be constructed in areas where some knowledge of the resource exists (specifically for resource exploration).

Stefansson (2002) used statistical methods to estimate investment costs of geothermal power plant construction using a 'stepwise' development. Under the stepwise development concept, perfect knowledge of the existing resource does not have to be in place prior to construction. Instead, a small power plant is constructed as part of initial phase of development. This plant can then be used to monitor and further estimate the production characteristics of the resource. Stefansson used existing data from plants already constructed in Iceland to estimate construction costs in unknown geothermal fields (costs were converted to U.S. dollars). Stefansson estimated both surface and subsurface costs for construction of a generic geothermal plant (no plant type was specified). However, only the costs associated with Stefanssons' surface equipment are shown in Table 3 because the assumptions in Stefanssons' subsurface costs were not consistent with the assumptions in this research.

Table 3. Cost Drivers for Binary Power Plants									
Source	Generating Equipment (\$/kW)	Pumps and Gathering System (\$/kW)	Resource Exploration (\$)	Well Drilling & Installation (\$/m)	Well Testing (\$)	Siting & Licensing (\$)	Annual O&M (%)	Plant Availability (%)	Plant Lifetime (yrs)
DiPippo, 1998	4,000								
	3,085								
	3,030								
Barbier, 2002				800					
				1,200					
Kutscher, 2000	1,600							95%	
								99%	
DoE Office of Energy Efficiency and Renewable Energy, Undated	1,468	74	3,200,000			3,200,000			30
Gawlik & Kutscher, 2000	2,466	85	45,000	648	30,000	50,000	4%		20
	3,358	381	45,000	1,029	30,000	50,000			
	3,999	634	45,000	1,029	30,000	50,000			
	3,558	392	45,000	1,029	30,000	50,000			
	2,572	123	45,000	1,029	30,000	65,000			
	3,025	269	45,000	1,029	30,000	59,488			
	3,519	173	45,000	582	30,000	50,000			
	3,006	208	45,000	1,029	30,000	50,000			
	2,894	220	45,000	1,029	30,000	65,000			
	3,038	286	45,000	1,677	60,000	65,000			
	3,394	544	45,000	2,705	90,000	65,000			
	3,909	544	45,000	1,029	30,000	50,000			
	3,803	634	45,000	1,677	60,000	50,000			
	2,148	67	45,000	648	30,000	61,360			
	2,794	90	45,000	582	30,000	50,000			
2,635	106	45,000	648	30,000	50,000				
2,673	147	45,000	1,029	30,000	65,000				
Stefansson, 2002	977							91%	
ORMAT ⁺	1,400			328					
				656					
Lovekin, 2000	2,000								20
	1800								30
Entingh, 1994			200,000	656			4%		30
				820					
				984					
NOTES:	+ Numbers provided in personal communication with Dan Schochet, Vice President of ORMAT Technologies								

Lovekins' (2000) study compared different plant size development scenarios in a hypothetical geothermal field. Lovekins' study showed that in field development, there is a tradeoff between plant size and the costs associated with keeping the field viable to sustain the desired output over time. Cost data associated with initial capital costs for generating equipment were listed in Table 3.

A report by Entingh et al. (1994) provided detailed cost and performance estimates for a 300kW geothermal power plant. Entingh estimated the effect various site conditions would have on the cost to produce electricity. The purpose of the report was to determine what conditions would make implementation and use of a small scale, off-grid geothermal production plant economically feasible.

III. Methodology

Overview

Payback periods and breakeven electricity sales rates were calculated for a binary power plant using costs associated with plant construction and operation. Figure 11 illustrates the relationships between the design and cost variables and how they influence the payback period and breakeven electricity sales rate under various conditions. Ovals shown in Figure 11 indicate input variables in the model. Shaded ovals indicate variables assigned probability distributions as opposed to discrete values. Key assumptions in the model development are:

- The type of plant is a binary cycle geothermal power plant
- A total of 2 wells (1 production and 1 injection) is assumed
- Ground temperature is held constant at 56°F (13°C) (average at 15 feet (4.5 meters) below ground surface for the U.S.)
- Heat loss from resource to heat exchanger is minimal

As illustrated in Figure 11, based on the selected resource temperature and geothermal gradient, and assuming a constant ground temperature, the required well depth to achieve the selected resource temperature was calculated using Equation 1. The resource temperature and the flow rate (at a given well diameter) were used to calculate the installed net generating capacity for each scenario. The electricity sales rate and the plant availability influences the annual revenue generated from the plant. The well depth and other fixed installation and equipment costs determine the initial capital costs as well as annual O&M costs.

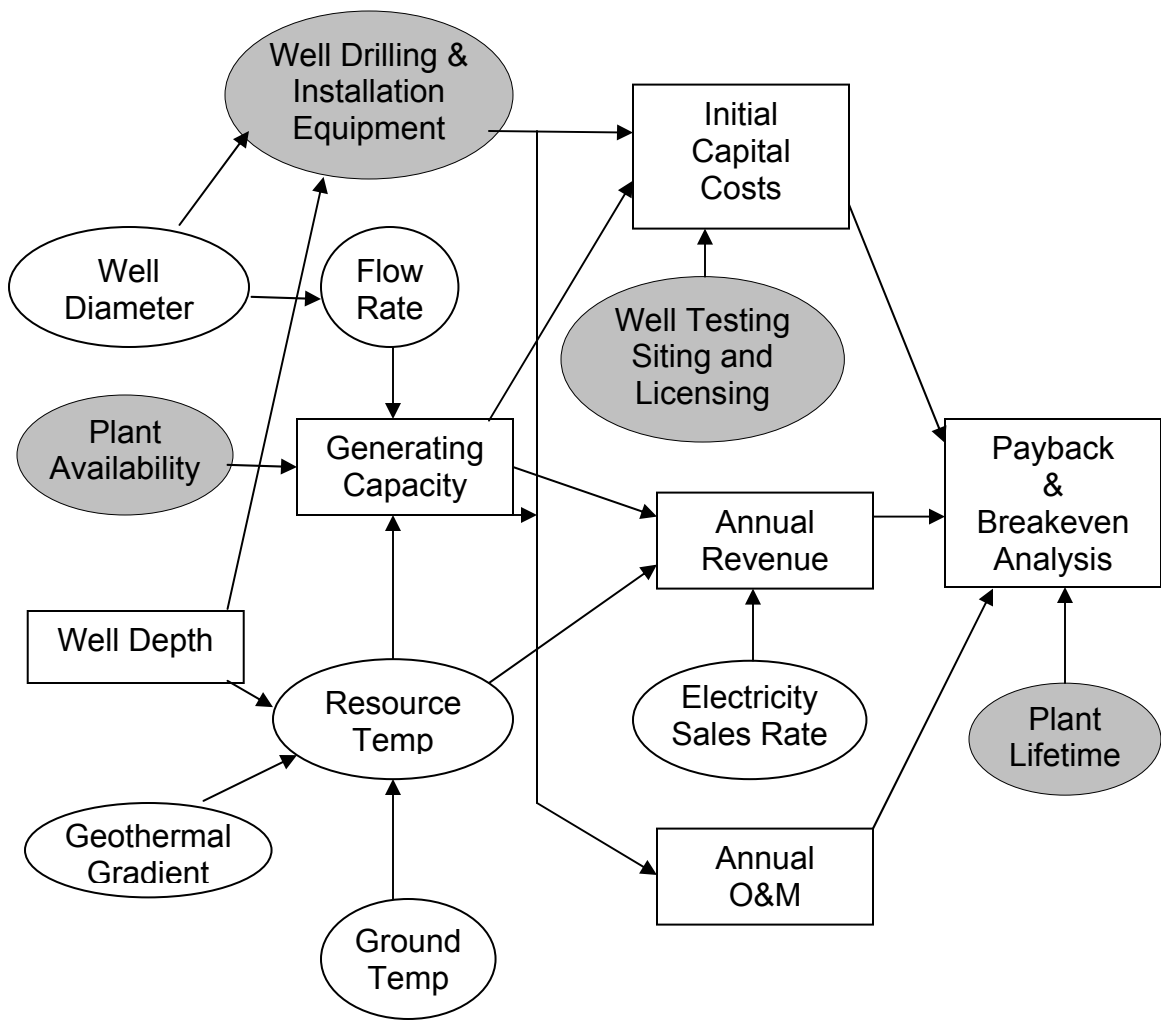

Figure 11. Methodology Influence Diagram

Nine different design scenarios were developed to represent different site conditions. The nine scenarios create a matrix as shown in Figure 12 based on a combination of 3 temperatures (160, 200, and 240°C) and 3 flow rates (322, 3,495, and 16,649 lit/min). As previously noted, these flow rates correspond to the optimal flow rates that can be achieved with a submersible pump for the three well diameters (100, 200, 300mm) selected for analysis (refer to Table 2). Within each of the nine scenarios, simple economic payback periods were calculated for five geothermal gradients (30, 40, 50, 60, 70°C/km) and 10 electricity sales rates (3-30 cents/kWh in 3 cent increments). The geothermal gradients used here were selected because they cover the middle to upper range of gradients in the U.S (refer to Figure 4). For example, given 160°C and a flow rate of 322 lit/min (optimal flow for 100mm well), the range of payback periods were calculated based on each geothermal gradient and each electricity sales rate.

	Flow Rate		
Resource Temp	322 lit/min	3,495 lit/min	16,649 lit/min
160°C	Scenario 1	Scenario 2	Scenario 3
200°C	Scenario 4	Scenario 5	Scenario 6
240°C	Scenario 7	Scenario 8	Scenario 9

Figure 12. Scenario Matrix

Payback Analysis

The simple economic payback period calculated by the model is a measure of the amount of time required to recover the initial capital costs of plant construction. The method used to calculate simple economic payback is shown in Equation 2.

$$\text{Payback (yrs)} = \frac{\text{Initial Capital Costs (\$)}}{\text{Annual Revenue (\$/yr)} - \text{Annual O \& M (\$/yr)}} \quad (2)$$

As can be seen from the equation, large annual revenues (either from high annual output or high electricity sales rates) result in smaller payback periods. The same is true if Annual O&M fees are small.

Breakeven Electricity Sales Rate Analysis

The breakeven analysis differs from the payback period analysis in that instead of calculating the amount of time necessary to recover initial costs, the actual electricity sales rate that must be achieved to recover the total life cycle costs of the plant was calculated. In other words, the breakeven sales rate computes the sales rate where the geothermal plant pays for itself. Total life cycle costs of the plant include initial capital costs as well as annual O&M fees. Annual O&M costs were converted from a series of payments over the lifetime of the plant to a single dollar amount using a present worth discount factor. The discount rate applied in this model is 3%, which is the approximate annual inflation rate in the U.S. The actual method used to calculate the breakeven electricity sales rate is shown in Equation 3.

$$\text{Breakeven Sales Rate (\$/kWh)} = \frac{\text{Total Life Cycle Cost (\$)}}{\text{Total Lifetime Output (kWh)}} \quad (3)$$

The breakeven sales rate (the amount electricity must be sold for in order to recover the total life cycle cost of the plant) was calculated for different geothermal gradients within each design scenario. The breakeven sales rate can be compared to applicable rates in the local area to determine competitiveness.

Variable Distribution Development

The variables shown in the shaded circles in Figure 11 impact the ultimate objectives of determining the payback period and breakeven sales rate for a binary cycle power plant. To account for the variability discussed in the literature review, probability distributions were developed for each of the variables as shown in Table 4.

Table 4. Distributions Assigned to Specific Cost Drivers			
Variable	Range Min	Range Max	Distribution Assigned
Generating Equipment (\$/kWh)	977	4000	Uniform
Pumps & Gathering System (\$/kWh)	67	634	Triangular with peak at 276
Resource Exploration (\$)	45,000	500,000	Uniform
Well Drilling & Installation (\$/m)	328	2705	Triangular with peak at 994
Well Testing (\$)	30,000	90,000	Uniform
Siting and Licensing (\$)	50,000	100,000	Uniform
Annual O&M (%)	3%	5%	Uniform
Plant Availability (%)	91%	99%	Uniform
Plant Lifetime (yrs)	20	30	Uniform

Generating equipment includes costs of the physical plant, including the turbine, generator, condenser, and heat exchanger. Generating equipment costs were scaled according to the installed net generating capacity of the plant (in units of \$/kW installed). As seen in Table 3, values for the generating equipment range from \$977/kW to \$4000/kW. A plot of the data, shown in Figure 13, shows that the reported data appears to be approximately evenly distributed with no apparent pattern or clustering; therefore, a uniform distribution ranging from \$997/kW to \$4000/kW was applied to this variable.

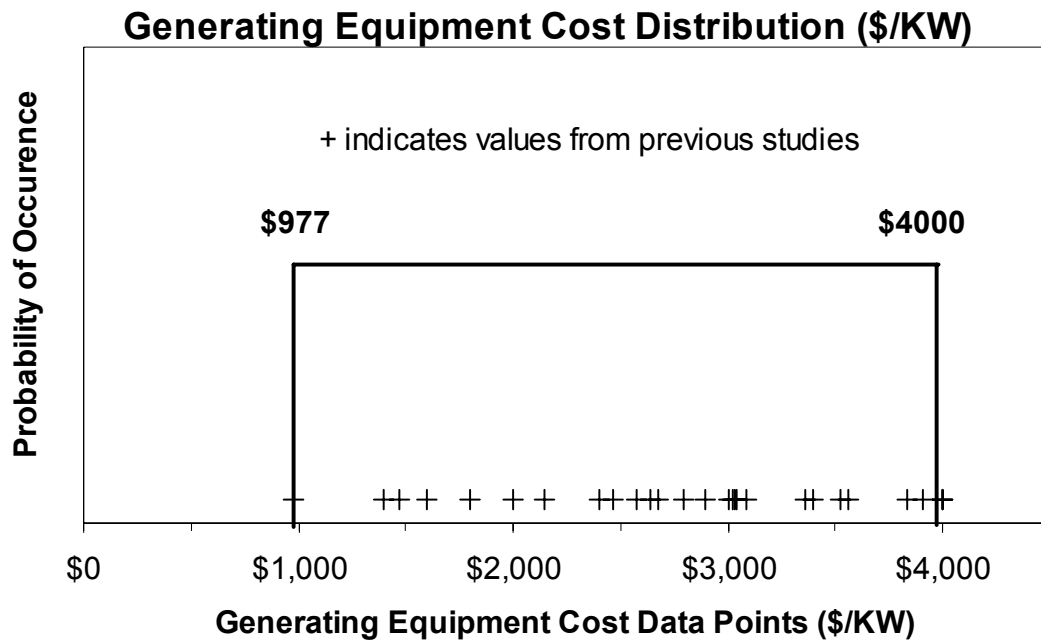

Figure 13. Cost Distribution for Generating Equipment

The pumps and gathering system consist of all equipment necessary to transport the fluid up the well and from the wellhead to the generating equipment. Values for this variable ranged from \$67/kW to \$634/kW, as shown in Figure 14.

Note that a majority of the data values fall below \$300/kW. To account for this clustering of data, a triangular distribution was selected using the endpoints of \$67/kW and \$634/kW as the minimum and maximum values with a peak value of \$276/kW, which is the average value of all the data.

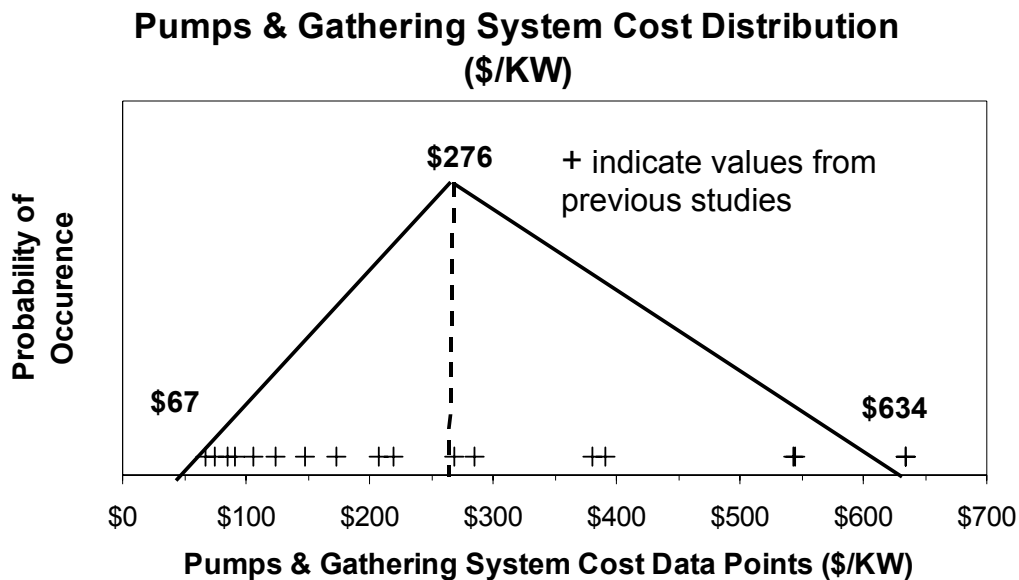

Figure 14. Cost Distribution for Pumps & Gathering System

Resource exploration costs include costs associated with identifying and classifying the resource. Table 3 shows a large disparity between reported resource exploration values. Gawlik and Kutscher (2000) recommend using \$45,000 for resource exploration, while data from the EERE (Undated) report estimates resource exploration costs at \$3,200,000. The reason for this disparity is based on the assumptions made in each study. Costs shown by Gawlik and Kutscher (2000) were calculated assuming that some knowledge of the resource

already exists (their study was based on a previous survey of existing geothermal sites), whereas the EERE (Undated) study included costs associated with identification of the resource with no previous information. It was assumed in this study that there was some knowledge of the geothermal resources. In other words, it is assumed that resources have been identified as likely candidates for future construction sites (but not yet developed). Eliminating the EERE study cost of \$3,200,000 results in a range maximum of \$200,000, though some sites may require more extensive research even with some prior knowledge. Therefore, a uniform distribution ranging from \$45,000 to \$500,000 was assigned to the resource exploration variable, which accounts for a wide range of possible costs.

Well drilling and installation costs include the costs of well drilling equipment and material (drill bits, well casing, etc.). Costs for this variable were calculated as a function of the well depth required to reach the selected resource temperature (in units of \$/m). In order to calculate the desired well depth, Equation 1 was rearranged to compute well depth given the site conditions (Equation 4).

$$\text{Well Depth(m)} = \frac{\text{Resource Temperature(Deg C)} - \text{Ground Temperature(Deg C)}}{\text{Geothermal Gradient(Deg C/km)} * 1000\text{m/km}} \quad (4)$$

Well drilling costs from the reviewed studies ranged from \$328/m to \$2705/m. A plot of the data, shown in Figure 15, shows that a number of points appear to cluster near \$1000/m. Therefore, a triangular distribution was applied

using a minimum value of \$328/m, a maximum value of \$2705/m, and a most likely value of \$994/m, which is the average of all values presented.

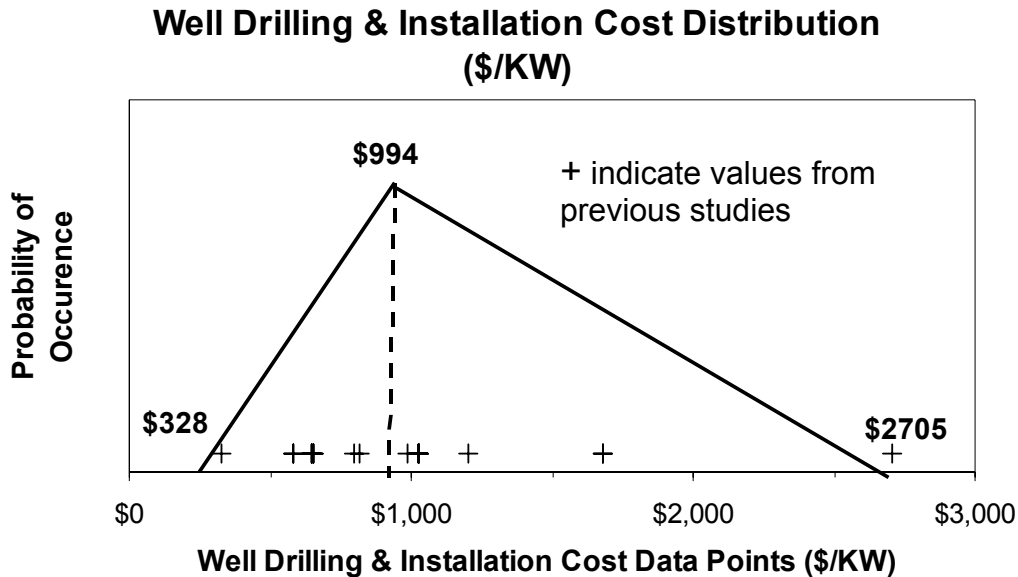

Figure 15. Cost Distribution for Well Drilling & Installation

Well testing costs include validating the condition of the well and the resource after the production well has been installed. Costs for this variable ranged from \$30,000 to \$90,000 in the Gawlik and Kutscher (2000) study. These numbers served as the minimum and maximum points for the uniform distribution applied here.

Table 3 indicates another large disparity between the values reported for costs associated with siting and licensing the plant. Gawlik and Kutscher (2000) values for this variable ranged from \$50,000 to \$65,000, while the EERE (Undated) study showed a value of \$3,200,000. Gawlik and Kutscher (2000) did

not account for costs associated with environmental impact statements, nor federal government licensing fees, which may account for the large difference in costs assigned to this variable. This study followed the Gawlik and Kutscher study, and assigned a uniform distribution based on their values (minimum of \$50,000 and maximum of \$65,000).

Annual O&M costs include maintenance of the field as well as the physical plant. To model this, annual O&M costs were calculated as a percentage of the total costs of the plant generating equipment, pumps and gathering system, as well as well drilling and installation costs. Only two values for this variable were seen in the reviewed data; however, both reports used 4% as the percentage assigned. However, to account for some variability and uncertainty associated with this cost, a uniform distribution was applied with a minimum value of 3% and a maximum value of 5%.

The plant availability factor is used in determining the payback period and breakeven sales rate. The plant availability factor is essentially the number of hours a plant is in operation over the total number of hours in a one year period, expressed as a percentage. This percentage was multiplied by the net generating capacity to calculate annual output (in kWh) of the plant; annual output was then used in conjunction with the selected utility sales rate to calculate the annual revenue the plant can generate. From the literature reviewed, binary cycle power plant availability factors ranged from 91% to 99%. Therefore, a uniform distribution between 91% and 99% was assumed.

Plant lifetime is a measure of how long the equipment and materials associated with the plant will remain serviceable. Plant lifetime, when multiplied by the annual output from the plant, gives a total lifetime output (in kWh). As seen in Equation 3, total lifetime output is an important variable in the determining the breakeven sales rate of the plant. Plant lifetime is also important in the payback period analysis. If the payback period extends beyond the plant lifetime, the construction and operation costs will never be recovered. The plant lifetime reported in other studies ranged from 20 to 30 years; therefore, a uniform distribution from 20-30 years was assumed in this analysis.

IV. Results

Overview

Results of the analysis were based on the output of the Monte Carlo simulation. Payback curves are shown for each scenario using the median value from the Monte Carlo output distributions. The output distributions for the breakeven analysis are presented as box-and-whiskers plots to facilitate comparison between the different design scenarios.

Figure 16 is an example of the output probability distribution for the simple economic payback period (in years) calculated for the scenario representing a resource temperature of 200°C and a flow rate of 3,495 lit/min, along with a geothermal gradient of 30°C/km and an electricity sales rate of 6 cents/kWh. The corresponding box-and-whiskers plot is shown along the bottom of the chart. The “whiskers” of the plot show the 2.5th and 97.5th percentile. The walls of the box represent the 25th and 75th percentile, and the line within the box represents the 50th percentile (median value).

Payback Analysis Results

Due to the volume of information calculated within each scenario, figures illustrating the results of the payback analysis show only the median (50th percentile) values. Tabular results showing the actual values for payback period distributions are shown in Appendix A. An example of the payback curves developed using the median values is shown in Figure 17. Notice that each of

Payback Period (yrs)
200°C, 3495 lit/min, 6 cents/kWh, 30°C/km

Frequency Chart

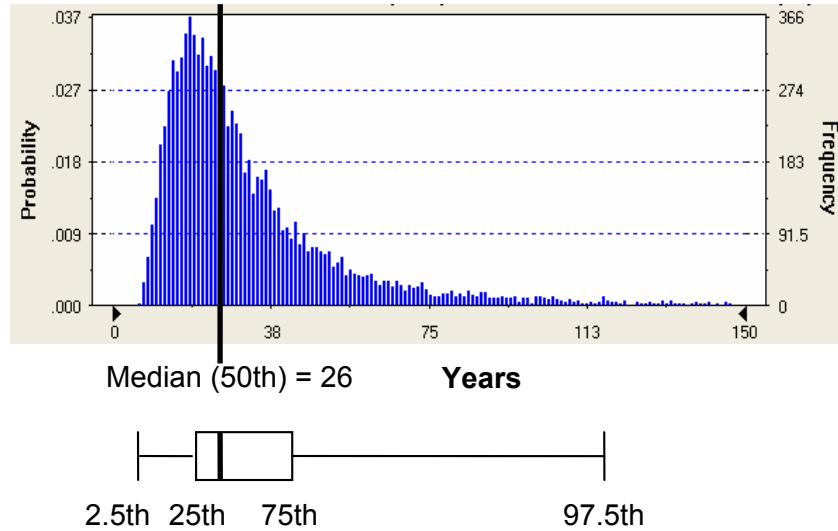
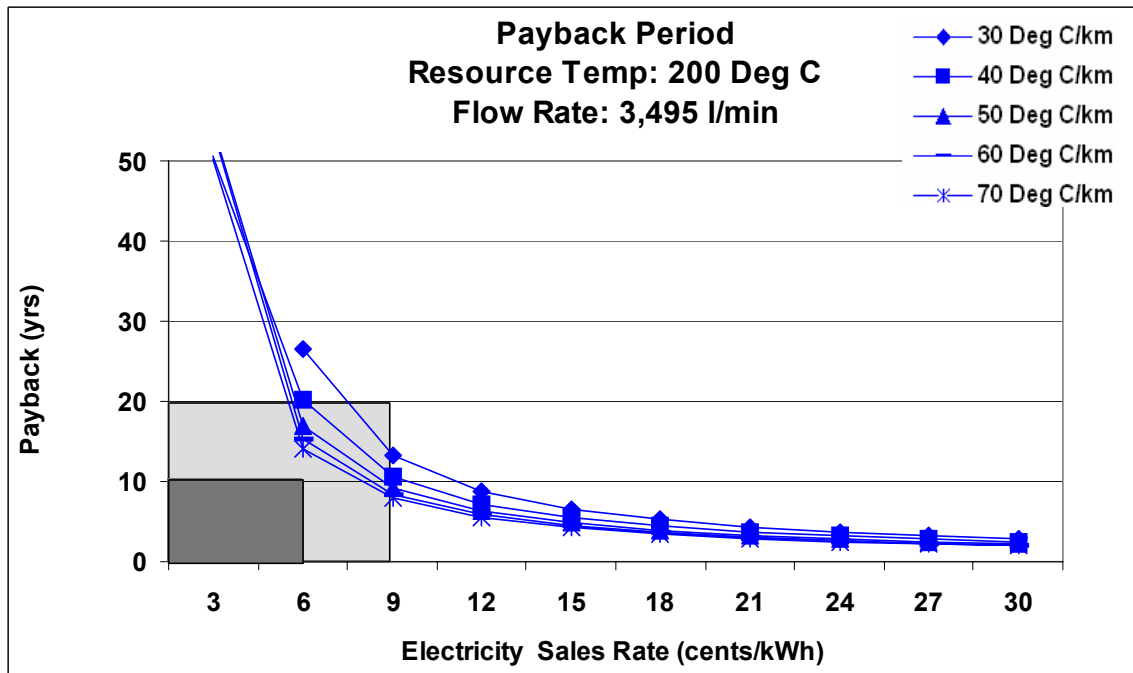

Figure 16. Sample Probability Distribution

the individual curves on the graph represents a unique geothermal gradient. In Figure 17, the median payback at 12 cents/kWh for all geothermal gradients modeled ranges from 6-9 years. However, when the price of electricity is only 9 cents/kWh, the median payback values range from 8-13 years. This is because the annual revenue at 9 cents/kWh is less than the revenue at 12 cents/kWh, which means 9 cents/kWh would take longer to payback the initial costs of constructing a geothermal system. Note also that the differences between the individual geothermal gradient curves are relatively small. This indicates that the



Note: The shaded areas represent desirable conditions. The darker box represents payback periods of less than 10 years when electricity prices are less than 6 cents/kWh (approximate national average). The light shaded box represents less than 20-year payback periods with electricity sales rates less than 9 cents/kWh.

Figure 17. Payback Curves for 200°C Resource Temperature and 3,495 lit/min Flow Rate

geothermal gradient for this scenario does not heavily influence the payback period, especially for electricity prices above 9 cents/kWh.

To receive funding, the Department of Defense requires energy projects to have a 10-year payback period or less (Air Force Civil Engineer Support Agency, 1999). Combining the 10-year or less payback period with the national average retail price of electricity in 2001 for all sectors of 6.64 cents/kWh creates a good target area for feasible payback periods (Department of Energy, 2001). Using these numbers as a basis for evaluation, ideal payback periods should be 10 years or less at 6 cents/kWh or less as shown graphically on Figure 17 by the

dark shaded box in the lower left hand corner. The box with lighter shading represents 20-year or less payback periods at 9 cents/kWh or less. Curves that pass within these shaded boxes are more preferable as they indicate shorter payback periods at expected electricity rates.

Constant Temperature Median Payback Periods

Figure 18 represents three separate flow rates at a constant temperature of 200°C. Note that the lowest flow rate of 322 lit/min does not have any desirable combination within the shaded boxes. In fact, payback periods for this flow rate do not drop below 20 years until the electricity sales rate reaches 21 cents/kWh for a geothermal gradient of 70°C/km. The solid lines for the middle flow rate of 3,495 lit/min are the same as those shown in Figure 17.

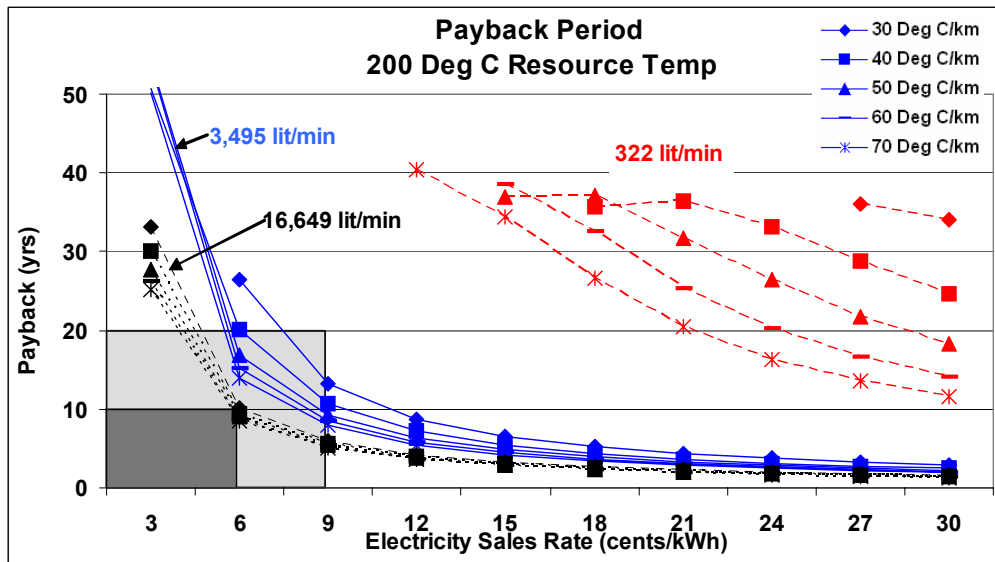

Note: The shaded areas represent desirable conditions. The darker box represents payback periods of less than 10 years when electricity prices are less than 6 cents/kWh (approximate national average). The light shaded box represents less than 20-year payback periods with electricity sales rates less than 9 cents/kWh.

Figure 18. Payback Curve Comparison Chart for 200°C Resource Temperature

The highest flow rate at 16,649 lit/min shows potential to have reasonably short payback periods (10 years or less) at expected electricity sales rates near 6 cents/KWh. This figure illustrates that the flow rate is a significant factor in the payback period of a geothermal plant. Also, at higher flow rates, the influence of different geothermal gradients becomes minor, particularly above electricity sales rates of 9 cents/kWh.

Graphs similar to Figure 18, which assumed 200°C, were plotted for each of the temperatures selected for analysis (160°C, 200°C, 240°C). These graphs are shown in Figure 19 for comparisons. As seen on the top chart in Figure 19, the combination of 160°C and 322 lit/min does not produce any payback period below 20 years for any of the geothermal gradients analyzed. In fact, the 322 lit/min flow rate appears to be impractical at any of the three temperatures modeled. However, the higher flow rates of 3,495 lit/min and 16,649 lit/min appear to have reasonable payback periods at expected electricity sales rates with the highest flow rate being slightly better. The influence of the five different geothermal gradients do not appear to be very significant at these higher flow rates as illustrated by the close proximity of each curve. The resource temperatures of 160°C, 200°C, and 140°C also do not appear to influence payback substantially because the curves for the middle and highest flow rates (3,495 and 16,649 lit/min) pass through the shaded areas at nearly the same locations for all three temperatures. It appears that the flow rate is the most

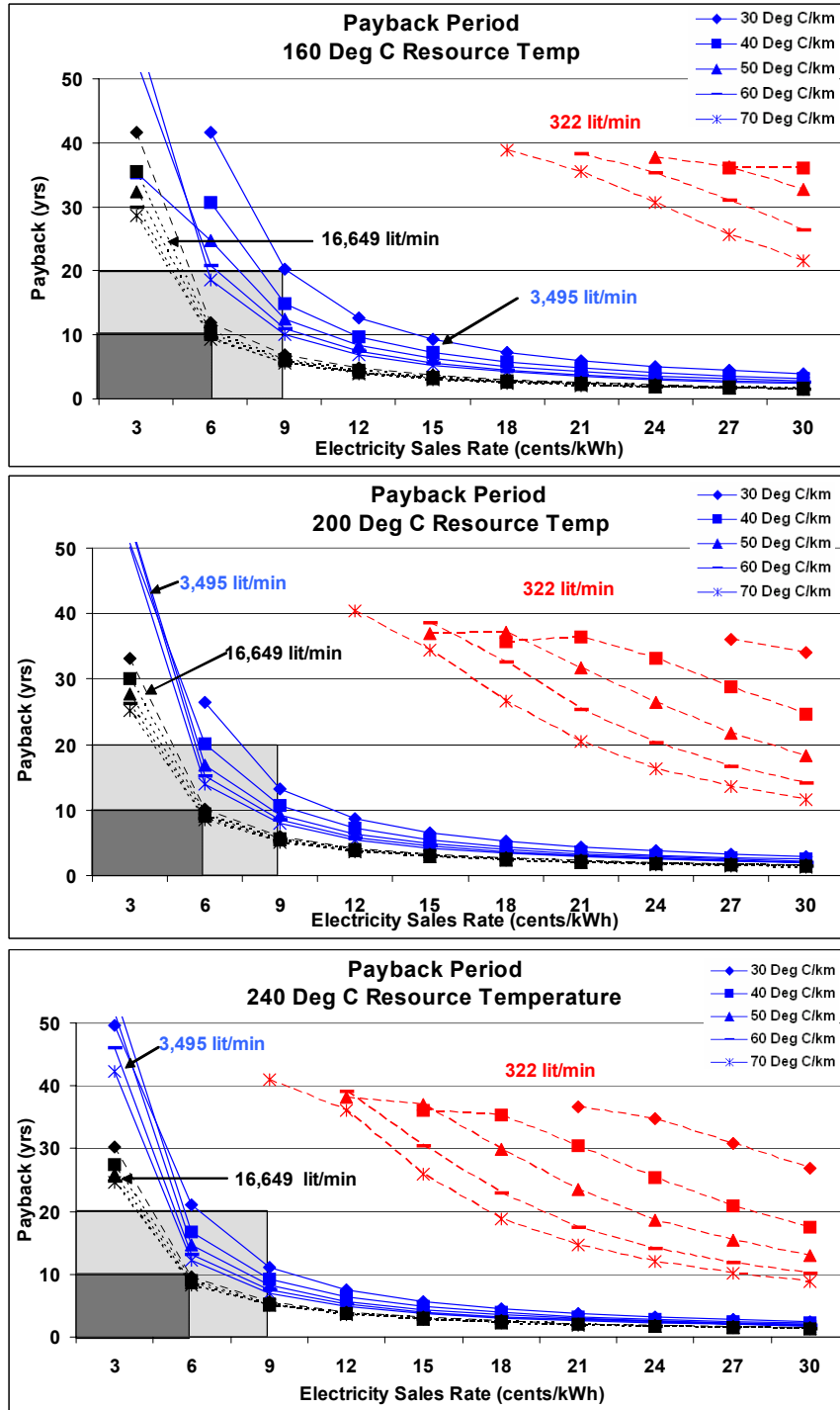

Note: The shaded areas represent desirable conditions. The darker box represents payback periods of less than 10 years when electricity prices are less than 6 cents/kWh (approximate national average). The light shaded box represents less than 20-year payback periods with electricity sales rates less than 9 cents/kWh.

Figure 19. Constant Temperature Payback Curve Comparison Charts

influential variable even over resource temperature and thermal gradient. This suggests that a large flow rate with a modest temperature may likely outperform a low flow rate at a high temperature.

Constant Diameter Median Payback Analysis

A different view of the data is to separate each curve based on flow rates for comparison as shown in Figure 20. This view shows more clearly that the lower flow rate of 322 lit/min is undesirable under almost any scenario. The center graph with the middle flow rate (3,495 lit/min) demonstrates that at 6 cents/kWh most site conditions will result in payback periods less than 20 years.

For the highest flow rate (16,649 lit/min) at 6 cents/kWh all site conditions would result in a payback period very close to 10 years. At 9 cents/kWh, all payback periods for each temperature fall below 10 years and only range from 5-7 years. This further demonstrates that at this flow rate, neither the resource temperature nor the geothermal gradient significantly changes the median payback period. The high flow rate (16,649 lit/min) graph shows that, regardless of geothermal gradient or resource temperature (within the range analyzed), lower payback periods can be achieved.

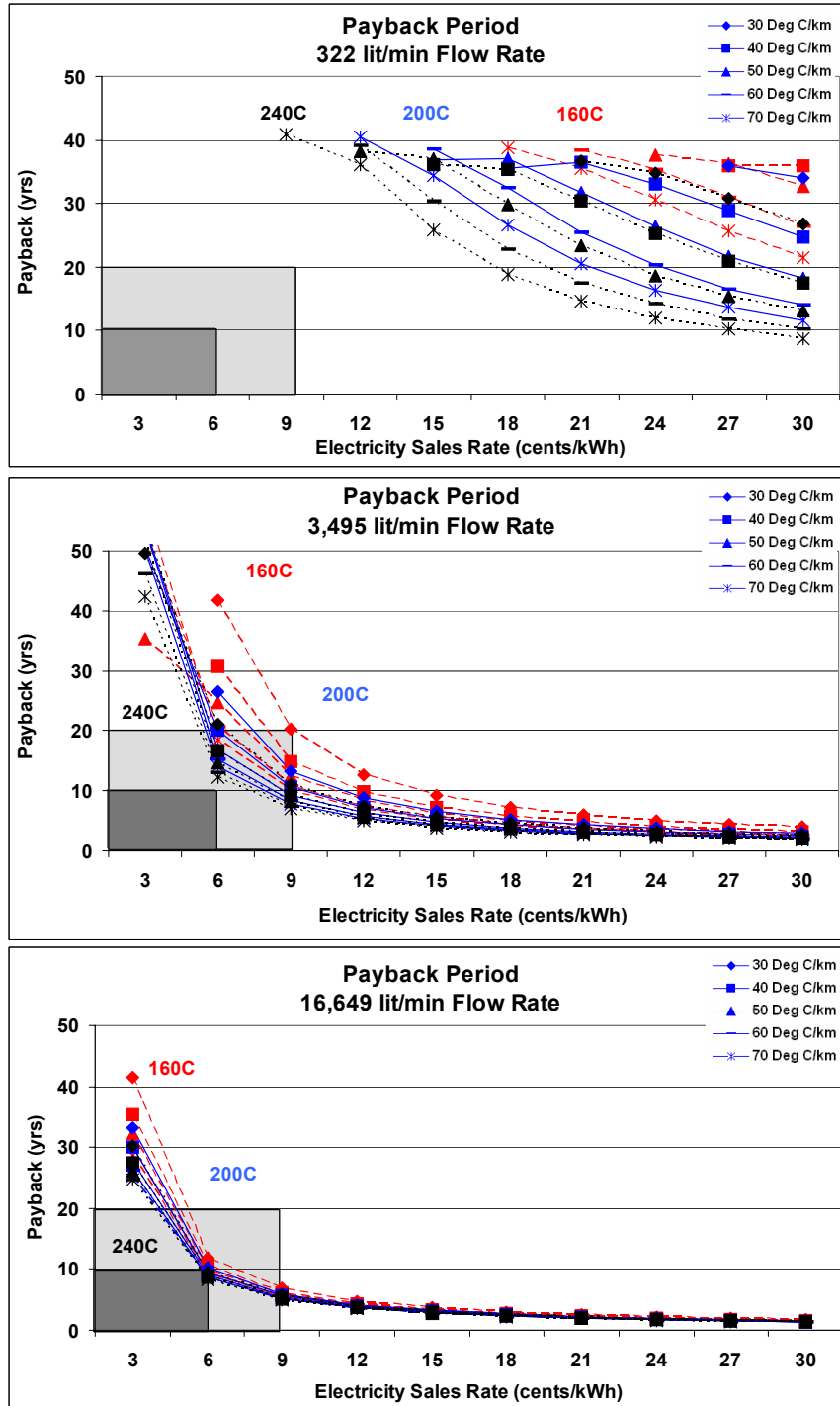

Note: The shaded areas represent desirable conditions. The darker box represents payback periods of less than 10 years when electricity prices are less than 6 cents/kWh (approximate national average). The light shaded box represents less than 20-year payback periods with electricity sales rates less than 9 cents/kWh.

Figure 20. Constant Flow Rate Payback Curve Comparison Charts

This implies that deeper drilling to obtain higher temperatures or developing in areas of high thermal gradients may not be important. With a high flow rate, the payback periods are low under many scenarios.

Breakeven Analysis Results

The electricity sales rates calculated in the breakeven analysis represent the price that electricity must be sold for in order to recover the total life cycle costs of the plant. In other words, the breakeven sales rate would be the minimum value customers would have to pay plant owners in order for them to “breakeven” over the lifetime of the plant. Results of the breakeven sales rates are presented as box-and-whisker plots for each geothermal gradient analyzed within each resource temperature/flow rate combination; tabular results for the breakeven sales rate distributions are shown in Appendix B. Figure 21 shows an example of the box-and-whisker plots for each geothermal gradient within the resource temperature/flow rate combination of 160°C/322 lit/min.

The box-and-whisker plots represent different percentiles calculated in the Monte Carlo simulation output probability distribution. The boxes along the right side of the graph show that the “whiskers” represent the 2.5th and 97.5th percentile, while the walls of the box represent the 25th and 75th percentile. The 50th percentile is the line within the walls of the box. Note also that the numbers presented in the graph show the median (50th percentile) breakeven sales rate for the particular conditions. For example, for the given conditions represented in

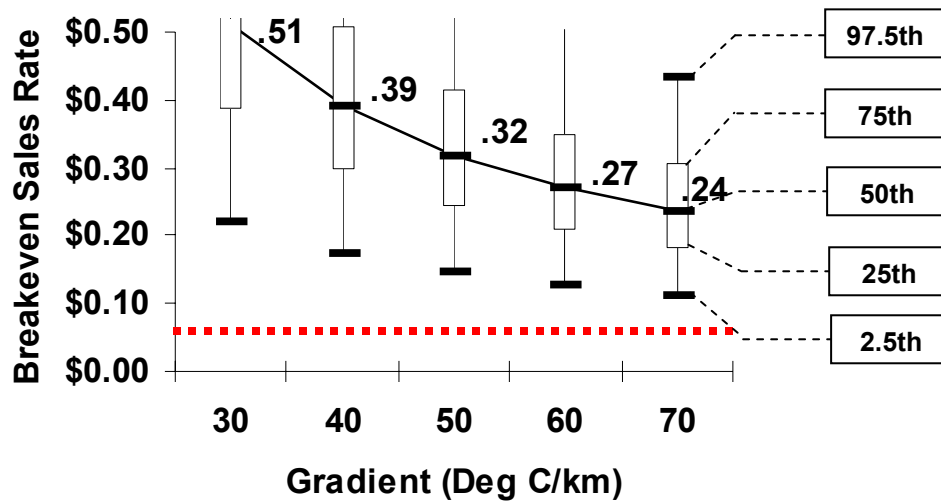

Note: The dotted line within the graph represents a target breakeven sales rate of 6 cents/kWh. The numbers shown within the graph represent the median (50th percentile) breakeven sales rates for each geothermal gradient. The percentiles associated with each line of the box and whisker plot are shown on the right hand side of the graph.

Figure 21. Breakeven Sales Rate Results for 160°C Resource Temperature and 322 lit/min Flow Rate

Figure 21 (160°C/322 lit/min), the median (50th percentile) breakeven sales rate for a 70°C/km geothermal gradient is 24 cents/kWh. Note that as the geothermal gradient decreases, the breakeven sales rate increases, which makes sense because as the geothermal gradient decreases, the depth to reach the resource temperature increases. This additional drilling depth adds cost in plant construction, increasing total life cycle costs, which in turn increases the sales rate that must be realized to recover those costs.

As mentioned earlier, the national average retail price of electricity in 2001 for all sectors was 6.64 cents/kWh (Department of Energy, 2001). Using this number as a basis for evaluation, ideal breakeven sales rates should be approximately 6 cents/kWh or less. This target value of 6 cents/kWh is shown

graphically in Figure 21 by the dotted line across the graph. Note in Figure 21 that no breakeven sales rates reach the target value, even at the highest geothermal gradient (70°C/km) and the lowest (2.5th) percentile. Notice also that the box-and-whiskers plots vary between each geothermal gradient, indicating that the geothermal gradient impacts the breakeven sales rates at this temperature and flow rate (160°C and 322 lit/min).

Figure 21 not only gives specific values for the expected breakeven sales rate, it also provides decision makers with a screening tool for use in determining whether site conditions support plant construction. For example, if local electricity sales rates in a location that has the physical conditions listed in the graph (resource temperature of 160°C, flow rate of 322 lit/min, and 70°C/km geothermal gradient) are less than 24 cents/kWh, construction of the plant is not feasible. However, if the local sales rate exceeds 24 cents/kWh, plant construction may be profitable.

The results of each resource temperature/flow rate combination are shown in Figure 22. Note that Figure 21 is the same graph shown in the upper, left block of Figure 22. Comparisons can be made between the various scenarios represented by each matrix block. The 160°C/322 lit/min block represents the worst-case scenario: low temperature and low flow rate. Comparing the calculated breakeven electricity sales rates to the target value of 6 cents/kWh in this scenario showed that these conditions were not favorable for construction. However, looking at the opposite extreme of the best-case scenario having the highest temperature and highest flow rate (240°C and 16,649 lit/min block), the

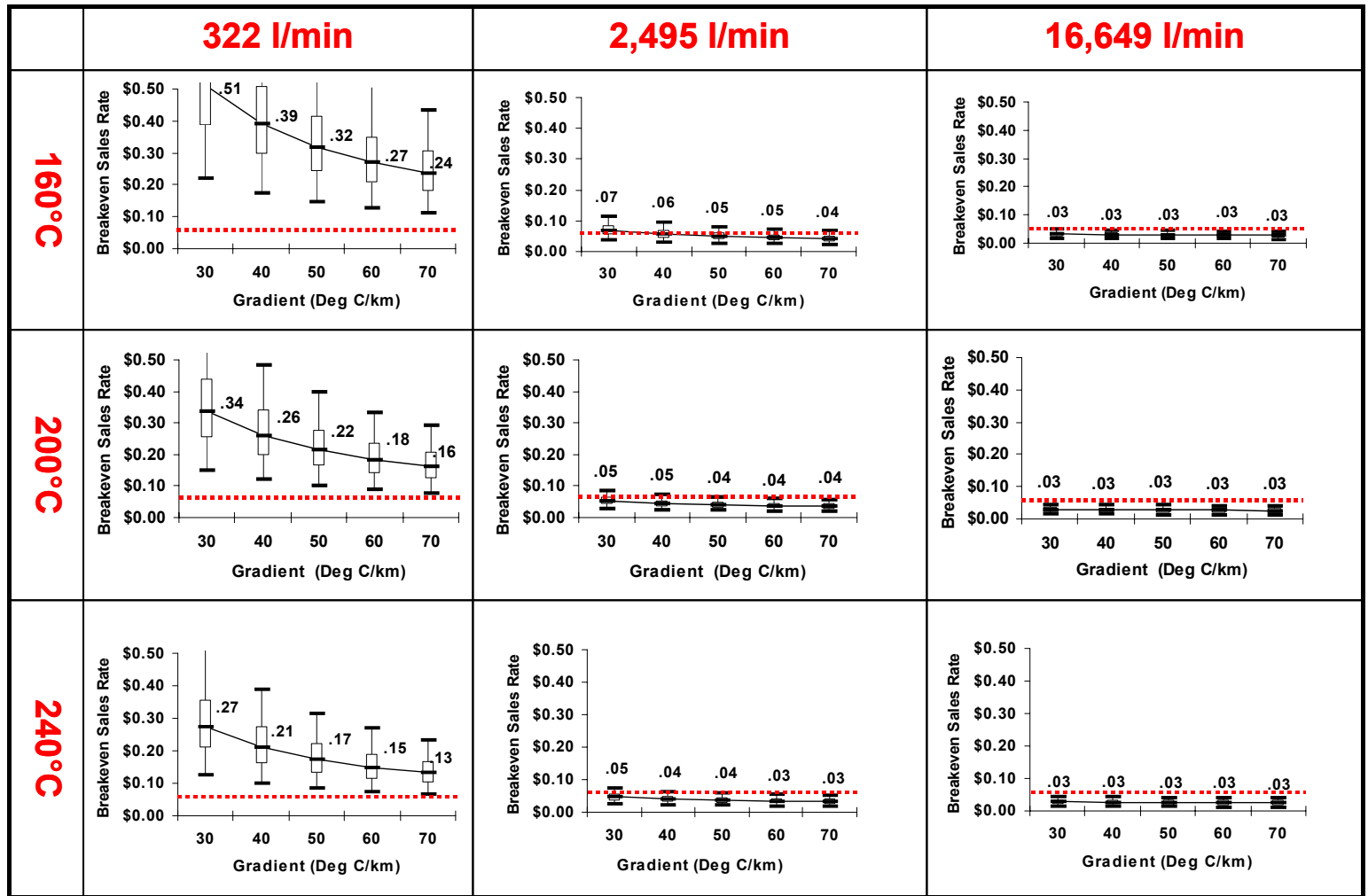

Note: Numbers shown represent the median (50th percentile) value for each geothermal gradient.

Figure 22. Breakeven Sales Rates by Scenario

results are markedly different. The 240°C/16,649 lit/min block (located at the extreme right on the bottom in Figure 22) shows that for all geothermal gradients evaluated, the median breakeven sales rate falls below the target rate of 6 cents/kWh. In fact, even the 97.5th percentile breakeven sales rates fall below the target value for all geothermal gradients within this scenario (the actual 97.5 percentile value is 4 cents/kWh for all geothermal gradients). In other words, given a temperature of 240°C and a flow rate of 16,649 lit/min, the model predicts a 97.5% chance that the breakeven sales rate will fall below 4 cents/kWh, regardless of the geothermal gradient.

As a further comparison, examine the middle block in Figure 22 (200°C/3,495 lit/min). This block represents a scenario halfway between the worst-case and best-case scenarios. As seen in the 200°C/3,495 lit/min block, all median breakeven sales rates are less than the target value of 6 cents/kWh. Only the 97.5th percentile value at the geothermal gradient of 30°C/km exceeds the target value. This graphically illustrates that given these site conditions, the geothermal gradient has little impact on the breakeven sales rate.

Figure 22 also illustrates the impact temperature and flow rate have on the breakeven sales rate. For example, at the 322 lit/min flow rate, the median breakeven sales rates exceed the target value for each temperature evaluated. In fact, for this flow rate, the breakeven sales rate does not fall below the target value of 6 cents/kWh even at the 2.5th percentile. This indicates that small flow rate does not produce the conditions necessary in order for the plant to be economically feasible. Notice also that the differences between the geothermal

gradient box-and-whisker plots in the 322 lit/min flow rate column vary greatly, indicating that at this flow rate, geothermal gradient has a significant impact on the breakeven sales rate. However, at the 3,459 lit/min and 16,649 lit/min flow rates, the breakeven sales rates are all very close to the U.S. average electricity rate of 6 cents/kWh.

V. Discussion

Different physical site characteristics that represent a broad range of possible sites were selected to create nine potential design scenarios. Each scenario represented a combination of a discrete resource temperature and well flow rate. Within each scenario, cost variables were used to calculate the median payback periods and breakeven sales rates. The cost variables were assigned probability distributions based on data from previous studies. By assigning probability distributions, the model produces a range of possible results. The range shown in the results more closely approximates a real-world situation where uncertainty and variability exists for each cost variable. Geothermal gradients representing the middle to upper end of the U.S. range were also evaluated within each scenario.

The selection of different site conditions, as well as specific cost variables, facilitated the calculation of payback periods for different electricity sales rates. By plotting the payback period vs. the electricity sales rate, it was possible to see how the different variables analyzed (resource temperature, well flow rate, geothermal gradient, and electricity sales rate) influenced the payback period.

While the results presented in this study are applicable to the specific site conditions selected for analysis, the model can be easily adapted to incorporate the conditions at any location. The specific site conditions can be updated to reflect the specific conditions, and the cost variable probability distributions can be updated to better reflect conditions at that location. However, the probability

distributions used here provide a good representation of many possible scenarios, and could be used as a general screening tool based on site conditions.

Limitations and Future Research

Several items were not considered in this study that may potentially impact the payback period and breakeven sales rate results. These limitations are listed below, and may be incorporated in future research studies.

1. This study assumes the plant owner is responsible for all costs associated with plant construction. The DoE offers several cost sharing programs that may help offset some of the initial construction costs associated with plant construction, which may impact the payback periods and breakeven sales rates calculated here.
2. Similarly, geothermal electricity production qualifies for an investment tax credit (ITC) that allows up to 10% of the initial investment costs to be claimed on an annual tax return. The savings associated with this ITC were not included here.
3. Costs associated with developing environmental impact statements were not included.
4. Costs of constructing transmission lines from the plant to the existing transmission system were not included.

5. This research focused only on a binary cycle geothermal power plant—similar analyses could be conducted for Dry Steam and Flash Steam plants.
6. Heat loss in the geothermal fluid as it moves from the resource to the heat exchanger was not considered.

Conclusions

The results of the simulation presented in this study provided insight into the impact different physical conditions have on both the payback period and breakeven sales rate. All resource temperatures evaluated in this study (160°C, 200°C, and 240°C) yielded payback periods that fall within the desired range (10 years or less at 6 cents/kWh) and breakeven sales rates that fall below the target value of 6 cents/kWh. As expected, the higher the resource temperature, the better the payback period and breakeven sales rate.

Of the flow rates evaluated (322, 3,459, and 16,649 lit/min), only the 3,459 lit/min and 16,649 lit/min cases yielded payback periods and breakeven sales rates within the desired range. The flow rate has a more significant impact on both the payback period and breakeven sales rate than did temperature for the ranges evaluated. This indicates that high flow rates may be more desirable than high temperatures when selecting a site for binary cycle geothermal power plant construction.

Geothermal gradients do influence the payback period and breakeven sales rate, particularly at low temperatures and low flow rates. However, as the

flow rate increased, the geothermal gradient had less impact at the highest flow rate evaluated (16,649 lit/min). In fact, payback periods and breakeven sales rates were nearly identical for all geothermal gradients evaluated at the high flow rate. Based on these results, areas with modest geothermal gradients (30°C/km) can yield desirable payback periods and breakeven sales rates with high flow rates. The results presented here indicate that a significant portion of the U.S. is suitable for geothermal development based on geothermal gradient. The geothermal gradient map of the U.S. in Figure 4 indicates that approximately half the U.S. has geothermal gradients above 30°C/km. However, flow rates must be considered at each location to better predict the economic feasibility of geothermal production at that location.

The resource temperature, flow rates, cost of electricity and geothermal gradients evaluated provide a good representation of typical conditions. However, these parameters may take on a broader range than those evaluated in this study. In fact, the cost of electricity is a variable that is highly uncertain. Though 6 cents/KWh was discussed frequently in this study, but higher values would shorten the payback period for geothermal electricity generation.

Appendix A. Payback Analysis Tabular Data

Payback Period (yrs)

Resource Temperature: 160°C

Flow Rate: 322 lit/min

Thermal Gradient		Electricity Sales Rate (cents/kWh)									
Deg/km	%iles	3	6	9	12	15	18	21	24	27	30
30	2.5										
30	25										
30	50										
30	75										82
30	97.5									921	912
40	2.5										
40	25										13
40	50									36	36
40	75									88	83
40	97.5							989	1018	1003	759
50	2.5										
50	25									18	19
50	50								38	36	33
50	75							88	85	78	67
50	97.5						998	937	927	728	509
60	2.5										6
60	25								20	19	17
60	50							38	35	31	26
60	75						93	82	71	59	48
60	97.5						947	737	629	410	246
70	2.5									7	7
70	25							20	18	16	14
70	50						39	35	31	26	21
70	75					91	87	73	59	46	36
70	97.5				1086	1065	915	595	388	216	126

Payback Period (yrs)

Resource Temperature: 160°C

Flow Rate: 3,495 lit/min

Thermal Gradient		Electricity Sales Rate (cents/kWh)									
Deg/km	%iles	3	6	9	12	15	18	21	24	27	30
30	2.5			8	6	4	4	3	3	2	2
30	25		25	14	10	7	6	5	4	4	3
30	50		42	20	13	9	7	6	5	4	4
30	75		79	30	17	12	9	8	6	6	5
30	97.5	877	518	74	30	19	14	11	9	8	7
40	2.5		11	7	5	4	3	3	2	2	2
40	25		21	11	8	6	5	4	3	3	3
40	50		31	15	10	7	6	5	4	4	3
40	75	100	50	20	13	9	7	6	5	4	4
40	97.5	1348	213	37	20	14	10	8	7	6	5
50	2.5		10	6	4	3	3	2	2	2	2
50	25		17	10	7	5	4	3	3	3	2
50	50	35	25	13	8	6	5	4	4	3	3
50	75	119	36	16	11	8	6	5	4	4	3
50	97.5	1218	100	27	16	11	9	7	6	5	5
60	2.5		9	5	4	3	2	2	2	2	1
60	25		15	9	6	5	4	3	3	2	2
60	50	53	21	11	7	6	5	4	3	3	3
60	75	130	29	14	9	7	5	5	4	3	3
60	97.5	1311	61	22	13	10	7	6	5	5	4
70	2.5		8	5	4	3	2	2	2	1	1
70	25	19	14	8	5	4	3	3	2	2	2
70	50	58	19	10	7	5	4	4	3	3	2
70	75	129	25	12	8	6	5	4	4	3	3
70	97.5	1323	46	19	12	9	7	6	5	4	4

Payback Period (yrs)

Resource Temperature: 160°C

Flow Rate: 16,649 lit/min

Thermal Gradient		Electricity Sales Rate (cents/kWh)									
Deg/km	%iles	3	6	9	12	15	18	21	24	27	30
30	2.5		6	3	3	2	2	1	1	1	1
30	25	25	9	5	4	3	2	2	2	2	1
30	50	42	12	7	5	4	3	3	2	2	2
30	75	74	16	9	6	5	4	3	3	2	2
30	97.5	395	23	12	8	6	5	4	3	3	3
40	2.5	12	5	3	2	2	1	1	1	1	1
40	25	22	8	5	3	3	2	2	2	1	1
40	50	35	11	6	4	3	3	2	2	2	2
40	75	61	14	8	5	4	3	3	2	2	2
40	97.5	283	20	10	7	5	4	4	3	3	2
50	2.5	11	5	3	2	2	1	1	1	1	1
50	25	20	7	4	3	2	2	2	1	1	1
50	50	32	10	6	4	3	3	2	2	2	2
50	75	53	13	7	5	4	3	3	2	2	2
50	97.5	204	19	10	7	5	4	3	3	3	2
60	2.5	11	4	3	2	2	1	1	1	1	1
60	25	19	7	4	3	2	2	2	1	1	1
60	50	30	9	6	4	3	3	2	2	2	1
60	75	50	13	7	5	4	3	3	2	2	2
60	97.5	174	18	9	6	5	4	3	3	2	2
70	2.5	10	4	3	2	2	1	1	1	1	1
70	25	18	7	4	3	2	2	2	1	1	1
70	50	29	9	6	4	3	2	2	2	2	1
70	75	47	12	7	5	4	3	3	2	2	2
70	97.5	146	17	9	6	5	4	3	3	2	2

Payback Period (yrs)

Resource Temperature: 200°C

Flow Rate: 322 lit/min

Thermal Gradient		Electricity Sales Rate (cents/kWh)									
Deg/km	%iles	3	6	9	12	15	18	21	24	27	30
30	2.5										
30	25									15	18
30	50									36	34
30	75								87	79	73
30	97.5						995	940	900	791	627
40	2.5										7
40	25								18	18	16
40	50						36	36	33	29	25
40	75						86	80	69	57	46
40	97.5					955	1012	837	596	390	233
50	2.5								7	7	7
50	25						19	19	17	14	12
50	50					37	37	32	26	22	18
50	75					88	80	63	48	37	29
50	97.5					939	755	455	260	146	84
60	2.5							8	7	6	6
60	25						20	16	14	12	10
60	50					39	33	25	20	17	14
60	75				96	81	62	44	33	26	21
60	97.5				1029	770	440	201	103	62	44
70	2.5						8	7	6	5	5
70	25					20	17	14	11	10	8
70	50				40	34	27	20	16	14	12
70	75				91	66	46	33	25	20	17
70	97.5			1197	963	479	255	108	60	41	31

Payback Period (yrs)

Resource Temperature: 200°C

Flow Rate: 3,495 lit/min

Thermal Gradient		Electricity Sales Rate (cents/kWh)									
Deg/km	%iles	3	6	9	12	15	18	21	24	27	30
30	2.5		10	6	4	3	3	2	2	2	2
30	25		19	10	7	5	4	4	3	3	2
30	50		26	13	9	7	5	4	4	3	3
30	75	113	40	17	11	8	6	5	5	4	4
30	97.5	1418	120	30	17	12	9	7	6	5	5
40	2.5		8	5	4	3	2	2	2	1	1
40	25		15	8	6	4	4	3	3	2	2
40	50	51	20	11	7	5	4	4	3	3	2
40	75	123	28	14	9	7	5	4	4	3	3
40	97.5	1129	59	21	13	9	7	6	5	4	4
50	2.5		7	5	3	3	2	2	2	1	1
50	25	25	12	7	5	4	3	3	2	2	2
50	50	54	17	9	6	5	4	3	3	2	2
50	75	118	23	12	8	6	5	4	3	3	3
50	97.5	1141	41	17	11	8	6	5	4	4	3
60	2.5		7	4	3	2	2	2	1	1	1
60	25	29	11	7	5	4	3	2	2	2	2
60	50	54	15	8	6	4	4	3	3	2	2
60	75	106	20	10	7	5	4	4	3	3	2
60	97.5	791	33	15	10	7	6	5	4	4	3
70	2.5		6	4	3	2	2	2	1	1	1
70	25	28	10	6	4	3	3	2	2	2	2
70	50	50	14	8	6	4	3	3	2	2	2
70	75	94	18	10	7	5	4	3	3	3	2
70	97.5	660	29	14	9	7	5	4	4	3	3

Payback Period (yrs)

Resource Temperature: 200°C

Flow Rate: 16,649 lit/min

Thermal Gradient		Electricity Sales Rate (cents/kWh)									
Deg/km	%iles	3	6	9	12	15	18	21	24	27	30
30	2.5	11	5	3	2	2	1	1	1	1	1
30	25	21	7	4	3	3	2	2	2	1	1
30	50	33	10	6	4	3	3	2	2	2	2
30	75	56	13	8	5	4	3	3	2	2	2
30	97.5	214	19	10	7	5	4	3	3	3	2
40	2.5	11	4	3	2	2	1	1	1	1	1
40	25	19	7	4	3	2	2	2	1	1	1
40	50	30	9	6	4	3	3	2	2	2	1
40	75	50	13	7	5	4	3	3	2	2	2
40	97.5	164	17	9	6	5	4	3	3	2	2
50	2.5	10	4	3	2	2	1	1	1	1	1
50	25	17	6	4	3	2	2	2	1	1	1
50	50	28	9	5	4	3	2	2	2	2	1
50	75	46	12	7	5	4	3	3	2	2	2
50	97.5	130	17	9	6	5	4	3	3	2	2
60	2.5	9	4	3	2	1	1	1	1	1	1
60	25	16	6	4	3	2	2	1	1	1	1
60	50	26	9	5	4	3	2	2	2	2	1
60	75	43	12	7	5	4	3	3	2	2	2
60	97.5	120	16	9	6	5	4	3	3	2	2
70	2.5	9	4	2	2	1	1	1	1	1	1
70	25	15	6	4	3	2	2	1	1	1	1
70	50	25	8	5	4	3	2	2	2	1	1
70	75	41	11	7	5	4	3	2	2	2	2
70	97.5	113	16	9	6	4	4	3	3	2	2

Payback Period (yrs)

Resource Temperature: 240°C

Flow Rate: 322 lit/min

Thermal Gradient		Electricity Sales Rate (cents/kWh)									
Deg/km	%iles	3	6	9	12	15	18	21	24	27	30
30	2.5										
30	25								18	18	16
30	50							37	35	31	27
30	75					77	87	84	74	61	49
30	97.5					903	1057	850	670	482	308
40	2.5								7	7	6
40	25						18	18	16	14	12
40	50					36	35	30	25	21	17
40	75					85	79	62	47	36	28
40	97.5				920	887	656	425	237	131	77
50	2.5							8	7	6	5
50	25					20	18	15	12	11	9
50	50				38	37	30	23	19	15	13
50	75				93	79	56	40	30	23	19
50	97.5				1099	693	350	162	84	53	39
60	2.5						8	7	6	5	4
60	25				19	19	15	12	10	9	7
60	50				39	30	23	18	14	12	10
60	75			97	81	57	38	27	21	17	15
60	97.5			1033	745	361	170	77	47	34	27
70	2.5					8	7	6	5	4	4
70	25				21	17	13	10	9	7	7
70	50			41	36	26	19	15	12	10	9
70	75			97	71	44	30	22	17	14	12
70	97.5			1025	627	195	80	45	32	25	20

Payback Period (yrs)

Resource Temperature: 240°C

Flow Rate: 3,495 lit/min

Thermal Gradient		Electricity Sales Rate (cents/kWh)									
Deg/km	%iles	3	6	9	12	15	18	21	24	27	30
30	2.5		9	5	4	3	2	2	2	2	1
30	25		15	9	6	5	4	3	3	2	2
30	50	50	21	11	7	6	5	4	3	3	3
30	75	127	30	14	9	7	5	5	4	3	3
30	97.5	1385	65	22	13	10	8	6	5	5	4
40	2.5		7	4	3	3	2	2	2	1	1
40	25	25	12	7	5	4	3	3	2	2	2
40	50	55	17	9	6	5	4	3	3	2	2
40	75	116	22	11	8	6	5	4	3	3	3
40	97.5	1049	40	17	11	8	6	5	4	4	3
50	2.5		7	4	3	2	2	2	1	1	1
50	25	28	11	6	4	3	3	2	2	2	2
50	50	52	15	8	6	4	4	3	3	2	2
50	75	100	19	10	7	5	4	4	3	3	2
50	97.5	744	31	14	9	7	6	5	4	3	3
60	2.5		6	4	3	2	2	1	1	1	1
60	25	27	10	6	4	3	3	2	2	2	1
60	50	46	13	7	5	4	3	3	2	2	2
60	75	85	17	9	6	5	4	3	3	2	2
60	97.5	561	27	13	8	6	5	4	4	3	3
70	2.5		6	4	3	2	2	1	1	1	1
70	25	26	9	5	4	3	2	2	2	2	1
70	50	42	12	7	5	4	3	3	2	2	2
70	75	76	16	9	6	5	4	3	3	2	2
70	97.5	484	24	12	8	6	5	4	3	3	3

Payback Period (yrs)

Resource Temperature: 240°C

Flow Rate: 16,649 lit/min

Thermal Gradient		Electricity Sales Rate (cents/kWh)									
Deg/km	%iles	3	6	9	12	15	18	21	24	27	30
30	2.5	10	4	3	2	2	1	1	1	1	1
30	25	19	7	4	3	2	2	2	1	1	1
30	50	30	10	6	4	3	3	2	2	2	1
30	75	51	13	7	5	4	3	3	2	2	2
30	97.5	175	18	9	6	5	4	3	3	2	2
40	2.5	10	4	3	2	2	1	1	1	1	1
40	25	17	6	4	3	2	2	2	1	1	1
40	50	27	9	5	4	3	2	2	2	2	1
40	75	44	12	7	5	4	3	3	2	2	2
40	97.5	137	17	9	6	5	4	3	3	2	2
50	2.5	9	4	3	2	1	1	1	1	1	1
50	25	16	6	4	3	2	2	2	1	1	1
50	50	26	9	5	4	3	2	2	2	2	1
50	75	42	12	7	5	4	3	2	2	2	2
50	97.5	115	16	9	6	4	4	3	3	2	2
60	2.5	9	4	2	2	1	1	1	1	1	1
60	25	15	6	4	3	2	2	1	1	1	1
60	50	25	8	5	4	3	2	2	2	1	1
60	75	40	11	7	5	4	3	2	2	2	2
60	97.5	104	15	8	6	4	4	3	3	2	2
70	2.5	9	4	2	2	1	1	1	1	1	1
70	25	15	6	4	3	2	2	1	1	1	1
70	50	25	8	5	4	3	2	2	2	1	1
70	75	40	11	6	5	4	3	2	2	2	2
70	97.5	98	15	8	6	4	4	3	3	2	2

Appendix B. Breakeven Sales Rate Analysis Tabular Results

Breakeven Sales Rates (\$/kWh)

Resource Temperature: 160°C

All Flow Rates

	Thermal Gradient		Flow Rate		
	Deg/m	%iles	322 l/min	3,495 l/min	16,649 l/min
160 Deg C	30	2.5	\$0.22	\$0.04	\$0.02
	30	25	\$0.39	\$0.06	\$0.03
	30	50	\$0.51	\$0.07	\$0.03
	30	75	\$0.67	\$0.08	\$0.04
	30	97.5	\$0.96	\$0.12	\$0.05
	40	2.5	\$0.17	\$0.03	\$0.02
	40	25	\$0.30	\$0.05	\$0.02
	40	50	\$0.39	\$0.06	\$0.03
	40	75	\$0.51	\$0.07	\$0.04
	40	97.5	\$0.74	\$0.09	\$0.05
	50	2.5	\$0.15	\$0.03	\$0.02
	50	25	\$0.24	\$0.04	\$0.02
	50	50	\$0.32	\$0.05	\$0.03
	50	75	\$0.41	\$0.06	\$0.04
	50	97.5	\$0.59	\$0.08	\$0.05
	60	2.5	\$0.13	\$0.03	\$0.01
	60	25	\$0.21	\$0.04	\$0.02
	60	50	\$0.27	\$0.05	\$0.03
	60	75	\$0.35	\$0.06	\$0.03
	60	97.5	\$0.50	\$0.07	\$0.04
70	2.5	\$0.11	\$0.02	\$0.01	
70	25	\$0.18	\$0.04	\$0.02	
70	50	\$0.24	\$0.04	\$0.03	
70	75	\$0.31	\$0.05	\$0.03	
70	97.5	\$0.44	\$0.07	\$0.04	

Breakeven Sales Rates (\$/kWh)

**Resource Temperature: 200°C
All Flow Rates**

	Thermal Gradient		Flow Rate		
	Deg/m	%iles	322 l/min	3,495 l/min	16,649 l/min
200 Deg C	30	2.5	\$0.15	\$0.03	\$0.02
	30	25	\$0.26	\$0.04	\$0.02
	30	50	\$0.34	\$0.05	\$0.03
	30	75	\$0.44	\$0.06	\$0.04
	30	97.5	\$0.64	\$0.08	\$0.05
	40	2.5	\$0.12	\$0.02	\$0.01
	40	25	\$0.20	\$0.04	\$0.02
	40	50	\$0.26	\$0.05	\$0.03
	40	75	\$0.34	\$0.05	\$0.03
	40	97.5	\$0.49	\$0.07	\$0.04
	50	2.5	\$0.10	\$0.02	\$0.01
	50	25	\$0.17	\$0.03	\$0.02
	50	50	\$0.22	\$0.04	\$0.03
	50	75	\$0.28	\$0.05	\$0.03
	50	97.5	\$0.40	\$0.06	\$0.04
	60	2.5	\$0.09	\$0.02	\$0.01
	60	25	\$0.14	\$0.03	\$0.02
	60	50	\$0.18	\$0.04	\$0.03
	60	75	\$0.24	\$0.05	\$0.03
	60	97.5	\$0.33	\$0.06	\$0.04
	70	2.5	\$0.08	\$0.02	\$0.01
70	25	\$0.13	\$0.03	\$0.02	
70	50	\$0.16	\$0.04	\$0.03	
70	75	\$0.21	\$0.04	\$0.03	
70	97.5	\$0.29	\$0.06	\$0.04	

Breakeven Sales Rates (\$/kWh)

**Resource Temperature: 240°C
All Flow Rates**

	Thermal Gradient		Flow Rate		
	Deg/m	%iles	322 l/min	3,495 l/min	16,649 l/min
240 Deg C	30	2.5	\$0.13	\$0.03	\$0.01
	30	25	\$0.21	\$0.04	\$0.02
	30	50	\$0.27	\$0.05	\$0.03
	30	75	\$0.35	\$0.06	\$0.03
	30	97.5	\$0.51	\$0.07	\$0.04
	40	2.5	\$0.10	\$0.02	\$0.01
	40	25	\$0.16	\$0.03	\$0.02
	40	50	\$0.21	\$0.04	\$0.03
	40	75	\$0.27	\$0.05	\$0.03
	40	97.5	\$0.39	\$0.06	\$0.04
	50	2.5	\$0.08	\$0.02	\$0.01
	50	25	\$0.14	\$0.03	\$0.02
	50	50	\$0.17	\$0.04	\$0.03
	50	75	\$0.22	\$0.04	\$0.03
	50	97.5	\$0.32	\$0.06	\$0.04
	60	2.5	\$0.07	\$0.02	\$0.01
	60	25	\$0.11	\$0.03	\$0.02
	60	50	\$0.15	\$0.03	\$0.03
	60	75	\$0.19	\$0.04	\$0.03
	60	97.5	\$0.27	\$0.05	\$0.04
	70	2.5	\$0.07	\$0.02	\$0.01
	70	25	\$0.10	\$0.03	\$0.02
	70	50	\$0.13	\$0.03	\$0.03
	70	75	\$0.17	\$0.04	\$0.03
	70	97.5	\$0.23	\$0.05	\$0.04

Bibliography

A-GRAM 99-22, *Plan to Meet FY2005 Energy Goals for Facility Energy*. Air Force Civil Engineer Support Agency, May 1999.

Anderson, David N. Geothermal Power Systems. Chapter in *Standard Handbook of Powerplant Engineering* (2nd Edition) Edited by Thomas C. Elliott, Kao Chen, and Robert. C. Swanekamp. New York, NY, McGraw-Hill, 1998.

Barbier, Enrico. "Geothermal Energy Technology and Current Status: An Overview," *Renewable and Sustainable Energy Reviews*, Vol 6: 3-65 2002.

Blackwell, David. D., Kenneth. W. Wisian and John. L. Steele. "Geothermal Resource/Reservoir Investigations Based on Heat Flow and Thermal Gradient Data for the United States." Department of Energy Geothermal Energy Technical Site, Research Summaries. n.pag.
<http://wastenot.inel.gov/geothermal/fy97/explore/exp-16.html>. 29 Jan, 2003.

Bureau of the Census. "World Population Information." Excerpt from unpublished article. n.pag. <http://blue.census.gov/ipc/www/world.html>. 13 Jan, 2003.

Clinton, William J. Executive Order 13123 *Greening the Government Through Efficient Energy Management*. Federal Register page and date: 64 FR 30851, June 1999. <http://www.nara.gov/fedreg/eo.html>

Combs, Jim. Geo Hills Associates LLC, Reno NV. Personal Communication. 19 March 2003.

Decisioneering, Inc. *Crystal Ball 2000.2 User Manual*. Denver Colorado, USA: Decisioneering, Inc., 2001.

Department of Energy. *Ground-Source Heat Pumps Applied to Commercial Facilities, Technology for Reducing Heating and Air-Conditioning Costs*. Federal Technology Alert, U.S. Department of Energy, 1994.

Department of Energy. *Annual Energy Review 2001*. Energy Information Administration. U.S. Department of Energy. 2002
<http://www.eia.doe.gov/emeu/aer/contents.html>.

Department of Energy. "Electricity Generation." Electric Power Industry Overview. n.pag. U.S. Department of Energy, 10 Aug 2002.
<http://www.eia.doe.gov/cneaf/electricity/page/prim2/chapter3.html#fossil>.

Department of Energy. *Annual Energy Outlook 2003 With Projections to 2025*. Report No. DOE/EIA-0383(2003). U.S. Department of Energy, 2003.
<http://www.eia.doe.gov/oiaf/aeo/index.html>

Department of Energy Office of Energy Efficiency and Renewable Energy. "Geothermal Hydrothermal." Excerpt from unpublished article. n.pag.
http://www.eere.energy.gov/power/pdfs/geo_hydro.pdf. 3 March, 2003.

DiPippo, Ronald. Geothermal Power Systems. Chapter in *Standard Handbook of Powerplant Engineering* (2nd Edition) Edited by Thomas C. Elliott, Kao Chen, and Robert. C. Swanekamp. New York, NY, McGraw-Hill, 1998.

Edinger, R. and S. Kaul. "Humankind's Detour Toward Sustainability: Past, Present, and Future of Renewable Energies and Electric Power Generation," *Renewable and Sustainable Energy Reviews*, Vol 4:295-313, 2000.

Entingh, Daniel. J., Easwaran E. and L. McLarty. "Small Geothermal Electric Systems for Remote Powering." *Geothermal Resources Council Bulletin*, Vol. 23, No. 10, Davis CA, November 1994.

Fridleifsson, I. B. "The Role of Geothermal Energy in the World," *Geo-Heat Center Quarterly Bulletin*, Vol 17, Iss 3: 1-5 31 Aug 1996.

Gawlik, K. and C. Kutscher. Investigation of the Opportunity for Small-Scale Geothermal Power Plants in the Western United States. National Renewable Energy Laboratory, Golden CO. March 2000.

Geothermal Education Office. "Introduction to Geothermal Energy Slide Show." Excerpt from unpublished article. n.pag. <http://geothermal.marin.org/GEOpresentation/>. 10 Jan, 2003.

Kutscher, Charles. F. "The Status and Future of Geothermal Electric Power," *American Solar Energy Society (ASES) Conference*. 9. Madison Wisconsin: National Renewable Energy Laboratory, 2000.

Lovekin, J. "The Economics of Sustainable Geothermal Development," *World Geothermal Congress Proceedings*: 843-848. Kyushu-Tohoku Japan: 2000.

Mock, J. E., J. W. Tester and P. M. Wright. "Geothermal Energy from the Earth: Its Potential Impact as an Environmentally Sustainable Resource," *Annual Review of Energy & the Environment*, Vol 22, Iss 1: 305-356 (31 Jan 1997).

National Energy Policy Development Group. *National Energy Policy: Reliable, Affordable, and Environmentally Sound Energy for America's Future*. May 2001.

Pierzynski, G. M., J. T. Sims and G. F. Vance. *Soils and Environmental Quality* Boca Raton, Florida: CRC Press, Inc, 1994.

Pritchett, John. W. "Mathematically Modeling Downhole Pump Performance in Geothermal Wells from 150 to 300 Millimeters Inside Diameter". Report Series Contract No. DE-FG-961D13455. U.S. Department of Energy, 1997.

Pritchett, John. W. "Electrical Generating Capacities of Geothermal Slim Holes." Report Series MSTD-DFR-98-16223. U.S. Department of Energy, 1998.

Stefansson, Valgardur. "Investment Cost for Geothermal Power Plants," *Geothermics*, Vol 31:263-272, 2002.

United States Congress. *Energy Policy Act of 1992*. Public Law No. 486, 102nd Congress, 1st Session. Washington: GPO, 1992.

Wright, P. M. "Geothermal Development in the U.S.A and Future Directions," *Energy Sources*, Vol 20, Iss 8: 733-741 31 Oct 1998.

Vita

Capt Crissie D. Fitzgerald graduated from South Summit High School in May 1991. She obtained her undergraduate degree in Civil Engineering from the United States Air Force Academy, and was commissioned a second lieutenant in the Air Force in 1995. Her first assignment was to the 90th Civil Engineer Squadron, F.E. Warren AFB, WY, where she served as a design engineer.

She was reassigned to the 92nd Civil Engineer Squadron at Fairchild AFB, WA, in August 1998, where she served as the Maintenance Engineering section chief, and later as the Readiness Flight Chief. In August 2001, she entered the Graduate School of Engineering and Management at the Air Force Institute of Technology. Upon graduation, she will be assigned to the 7th Air Force at Osan AB, South Korea.

REPORT DOCUMENTATION PAGE			Form Approved OMB No. 074-0188		
<p>The public reporting burden for this collection of information is estimated to average 1 hour per response, including the time for reviewing instructions, searching existing data sources, gathering and maintaining the data needed, and completing and reviewing the collection of information. Send comments regarding this burden estimate or any other aspect of the collection of information, including suggestions for reducing this burden to Department of Defense, Washington Headquarters Services, Directorate for Information Operations and Reports (0704-0188), 1215 Jefferson Davis Highway, Suite 1204, Arlington, VA 22202-4302. Respondents should be aware that notwithstanding any other provision of law, no person shall be subject to a penalty for failing to comply with a collection of information if it does not display a currently valid OMB control number.</p> <p>PLEASE DO NOT RETURN YOUR FORM TO THE ABOVE ADDRESS.</p>					
1. REPORT DATE (DD-MM-YYYY) 25-03-2003		2. REPORT TYPE Master's Thesis		3. DATES COVERED (From - To) Jun 2002 - Mar 2003	
4. TITLE AND SUBTITLE AN ECONOMIC EVALUATION OF BINARY CYCLE GEOTHERMAL ELECTRICITY PRODUCTION			5a. CONTRACT NUMBER		
			5b. GRANT NUMBER		
			5c. PROGRAM ELEMENT NUMBER		
6. AUTHOR(S) CRISSIE D. FITZGERALD, Capt, USAF			5d. PROJECT NUMBER		
			5e. TASK NUMBER		
			5f. WORK UNIT NUMBER		
7. PERFORMING ORGANIZATION NAMES(S) AND ADDRESS(S) Air Force Institute of Technology Graduate School of Engineering and Management (AFIT/EN) 2950 P Street, Building 640 WPAFB OH 45433-7765			8. PERFORMING ORGANIZATION REPORT NUMBER AFIT/GEE/ENV/03-07		
9. SPONSORING/MONITORING AGENCY NAME(S) AND ADDRESS(ES) HQ AFCESA/CESM Attn: Mr. Mike Santoro 139 Barnes Drive Suite 1 DSN: 523-6463 Tyndall AFB, FL 32403-5319 e-mail: mike.santoro@tyndall.af.mil			10. SPONSOR/MONITOR'S ACRONYM(S)		
			11. SPONSOR/MONITOR'S REPORT NUMBER(S)		
12. DISTRIBUTION/AVAILABILITY STATEMENT APPROVED FOR PUBLIC RELEASE; DISTRIBUTION UNLIMITED.					
13. SUPPLEMENTARY NOTES					
14. ABSTRACT The U.S. is dependent on fossil fuels to produce electricity. Using geothermal energy for electricity production can reduce fossil fuel dependence. The economic analysis presented in this study focuses on binary cycle geothermal electricity production. Variables such as flow rate, geothermal gradient and electricity prices were varied to study their influence on the payback period for binary cycle geothermal electricity production. Payback periods represent the time necessary to recover initial costs of plant construction. Flow rate has the greatest influence on economic results. A 10-year payback period can be achieved with almost any scenario as long as the electricity sales rates are above 6 cents/kWh and the well flow rate is high (16,649 lit/min). At a modest flow rate (3,459 lit/min), most scenarios have payback periods below 20 years as long as sales rates are above 6 cents/kWh. However, at the lowest flow rate (320 lit/min), no scenario results in a payback less than 20 years unless electricity sales prices reach at least 17 cents/kWh. Because geothermal gradient is not as influential as flow rate, a large fraction of the U.S. with modest thermal gradients can economically produce geothermal electricity as long as site conditions allow high flow rates.					
15. SUBJECT TERMS Electricity, Economic Analysis, Energy, Thermoelectric Power Generation, Electric Power Production, Thermal Power Plants, Energy Consumption, Life Cycle Costs, Rankine Cycle, Geothermy					
16. SECURITY CLASSIFICATION OF:			17. LIMITATION OF ABSTRACT UUU	18. NUMBER OF PAGES 80	19a. NAME OF RESPONSIBLE PERSON Alfred E. Thal, Jr., Lt Col, USAF (ENV)
a. REPORT U	b. ABSTRACT U	c. THIS PAGE U			19b. TELEPHONE NUMBER (Include area code) (937) 785-3636 ext. 4591; e-mail: alfred.thal@afit.edu

Standard Form 298 (Rev. 8-98)
Prescribed by ANSI Std. Z39-18